

# TOW-BEHIND LAWN SWEEPER



## Instruction & Assembly

SAVE THESE INSTRUCTIONS FOR FUTURE REFERENCE

# Table of Contents

General Warnings and Rules.....	3, 4
Controls and Features Identification.....	5
Components & Hardware.....	6, 7
Assembly Instructions.....	8, 9 10, 11, 12, 13, 14
Operation Instructions.....	15
Maintenance and Storage.....	16, 17
Specifications.....	18
Parts Drawing & Parts List.....	19, 20, 21, 22
Limited Warranty.....	23

## **GENERAL WARNINGS**

### **READ and UNDERSTAND this manual completely before using the Lawn Sweeper.**

Operator must read and understand all safety and warning information, operating instructions, maintenance and storage instructions, before operating this equipment. Failure to properly operate and maintain the lawn sweeper could result in serious injury to the operator and/or bystanders.

#### **Operation Warnings**

- Do not use the sweeper to carry passengers and never sit or stand on the lawn sweeper.
- Do not allow children to play on, stand upon, or climb on the lawn sweeper.
- Only connect the hopper rope to the tow vehicle. Do not connect the hopper rope to anything else.
- Always keep body parts clear from and clothing detached from the sweeper and rope.
- Always inspect the sweeper before use to assure that it is in good working condition.
- Replace or repair damaged or worn parts immediately.
- Always check and tighten hardware and assembled parts before operation.
- Avoid large holes and ditches when operating the equipment.
- Be careful when operating the sweeper on steep grades (hills).
- Always operate up and down the slope. Never operate across the face of the slope.
- Always operate at reduced speed in rough terrain, along creeks, ditches and on hillsides.
- Do not operate close to creeks, ditches, or public highways.
- To avoid personal injury and/or equipment damage **DO NOT EXCEED 5MPH.**
- Always use caution when loading and unloading the hopper.
- Only tow with recommended vehicles (Lawn/Garden Tractors and ATVs).
- Always refer to the vehicle owner's manual for proper towing.
- Sweeper is not designed to be used with zero-turn mowers.
- Always secure and lock sweeper to the vehicle hitch before operating.

#### **Crush and Cut Hazards**

- Always keep hands and feet clear from moving parts while operating the equipment.
- Always clear and keep work area clean when operating.
- Always wear safety gear, eye protection, gloves, and work boots when operating the sweeper.

### **WARNING**

The warnings, cautions, and instructions outlined in this instruction manual cannot cover all possible conditions or situations that may occur. It must be understood by the operator that common sense and caution are factors which cannot be built into this product and must be supplied by the operator.





### **PROP 65 WARNING**

This product can expose you to chemicals including lead and lead compounds which are known to the State of California to cause cancer and birth defects or other reproductive harm. For more information, go to [www.P65Warnings.ca.gov](http://www.P65Warnings.ca.gov).

#### **Assembly Is Required**

This product must be assembled before use. Please see the "Assembly" section for detailed instructions. Given the weight and size of the lawn sweeper, it is recommended that at least two able bodied adults assist in assembly. Upon receipt closely **INSPECT ALL COMPONENTS** to be sure no components are missing and/or damaged.

# Hazard Signal Word Definitions

	<p>This is the safety alert symbol. It is used to alert you to potential personal injury hazards. Obey all safety messages that follow this symbol to avoid possible injury or death.</p>
	<p><b>DANGER</b> indicates an imminently hazardous situation which, if not avoided, will result in death or serious injury.</p>
	<p><b>WARNING</b> indicates a potentially hazardous situation which, if not avoided, could result in death or serious injury.</p>
	<p><b>CAUTION</b> indicates a potentially hazardous situation which, if not avoided, may result in minor or moderate injury.</p>
	<p><b>CAUTION</b> used without the safety alert symbol indicates a potentially hazardous situation which, if not avoided, may result in property damage.</p>

## ABOUT YOUR TOW-BEHIND LAWN SWEEPER

This heavy-duty tow-behind lawn sweeper makes yard work a breeze. The steel and nylon construction are durable and lightweight, making it wear and rust-resistant, easy to tow, and easy to clean. The extra-large sweeping span makes jobs easy and saves time when cleaning different types of debris, from grass clippings, twigs, and leaves, to paper and much more. The tow-behind sweeper features a one-handed lever to adjust the brush height. It can be stored in a shed or garage with minimal space. The large hopper makes loading and unloading fast and convenient.

Technical specifications on the lawn sweeper are found in the “Specifications” section of this manual.

## Controls and Features Identification

Read this owner's manual before operating the equipment. Familiarize yourself with the location and function of the controls and features. Save this manual for future reference.

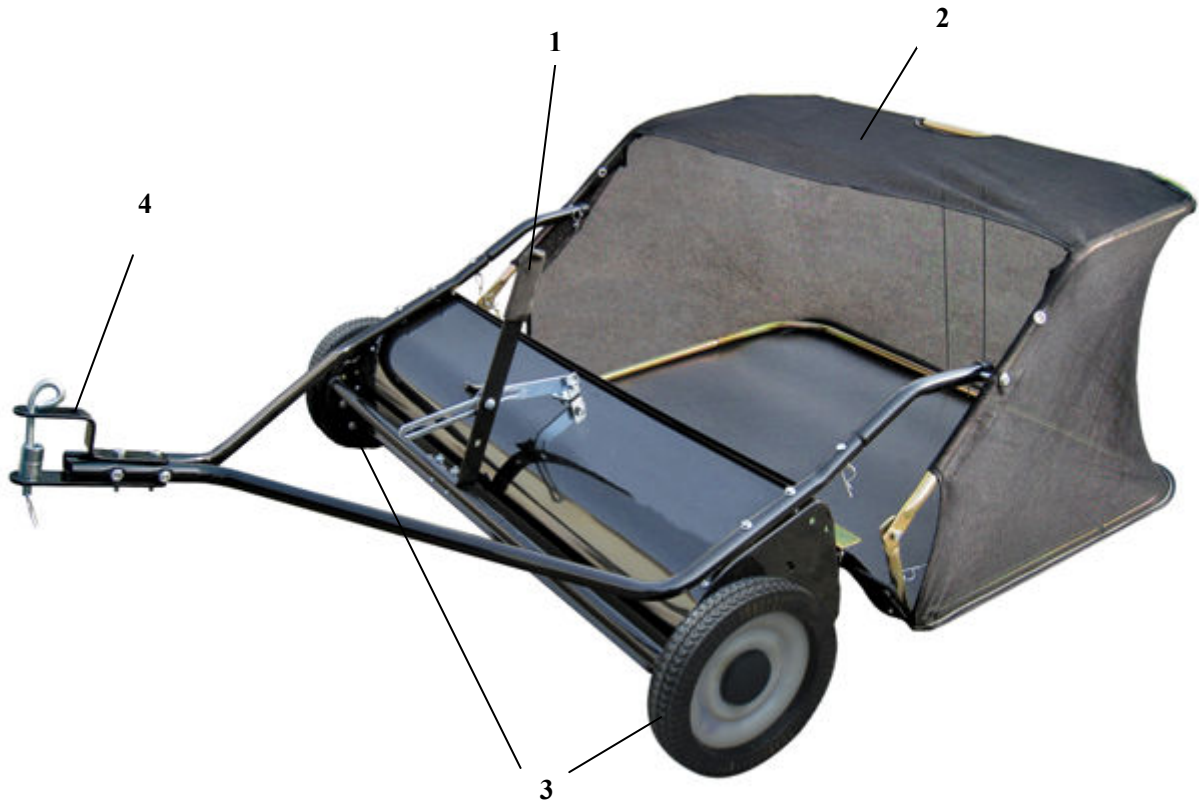

- 1) **Hand Lever** – Adjust the Brush Height.
- 2) **Nylon Hopper** – Holds all types of Debris.
- 3) **Tires / Wheels** – Semi pneumatic all terrain tires.
- 4) **Hitch** – Pin-type design; use only with approve vehicles.



## CAUTION

Read and follow all instructions for assembly and operation. Failure to properly assemble this equipment could result in serious injury to the operator and/or bystanders and may cause equipment damage.

### LAWN SWEEPER COMPONENT PARTS AND ASSEMBLY

Before starting to assemble the sweeper, remove all parts from the shipping crate and inspect components to ensure there are no missing or damaged pieces. After inspecting components proceed to "Assembly" and complete steps 1 through 9.

#### TOOLS REQUIRED

- 10, 13 & 14mm Wrenches
- Pliers

## Component and Hardware Parts

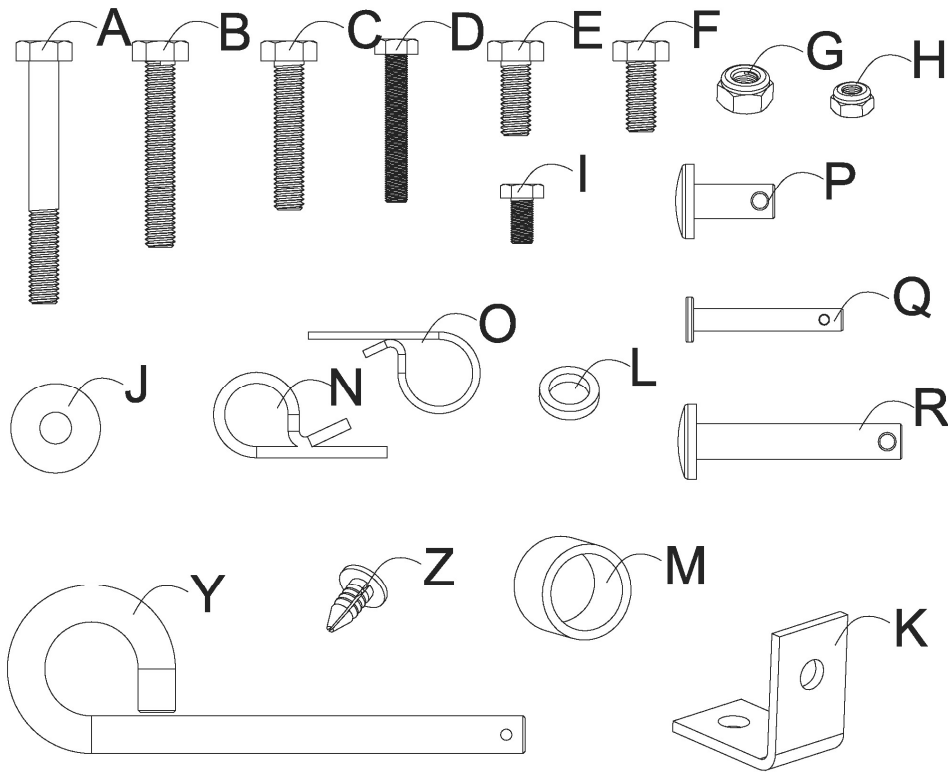

REF.	QTY.	DESCRIPTION	REF.	QTY.	DESCRIPTION
A	2	Hex Bolt M8x65	K	1	Angle Bracket
B	2	Hex Bolt M8x50	L	1	Adjustable Pole Spacer
C	2	Hex Bolt M8x40	M	2	Hitch Spacer
D	4	Hex Bolt M6x40	N	5	R Pin Ø3
E	1	Hex Bolt M8x20	O	4	R Pin Ø2
F	1	Hex Bolt M8x16	P	2	Clevis Pin Ø9.5x25
G	8	Nylon Lock Nut M8	Q	4	Clevis Pin Ø6x37
H	6	Nylon Lock Nut M6	R	2	Clevis Pin Ø8x59.5
I	2	Hex Bolt M6x12	Y	1	Hitch Pin
J	1	Big Flat Washer Ø8	Z	4	Plastic Plug

## Component and Hardware Parts

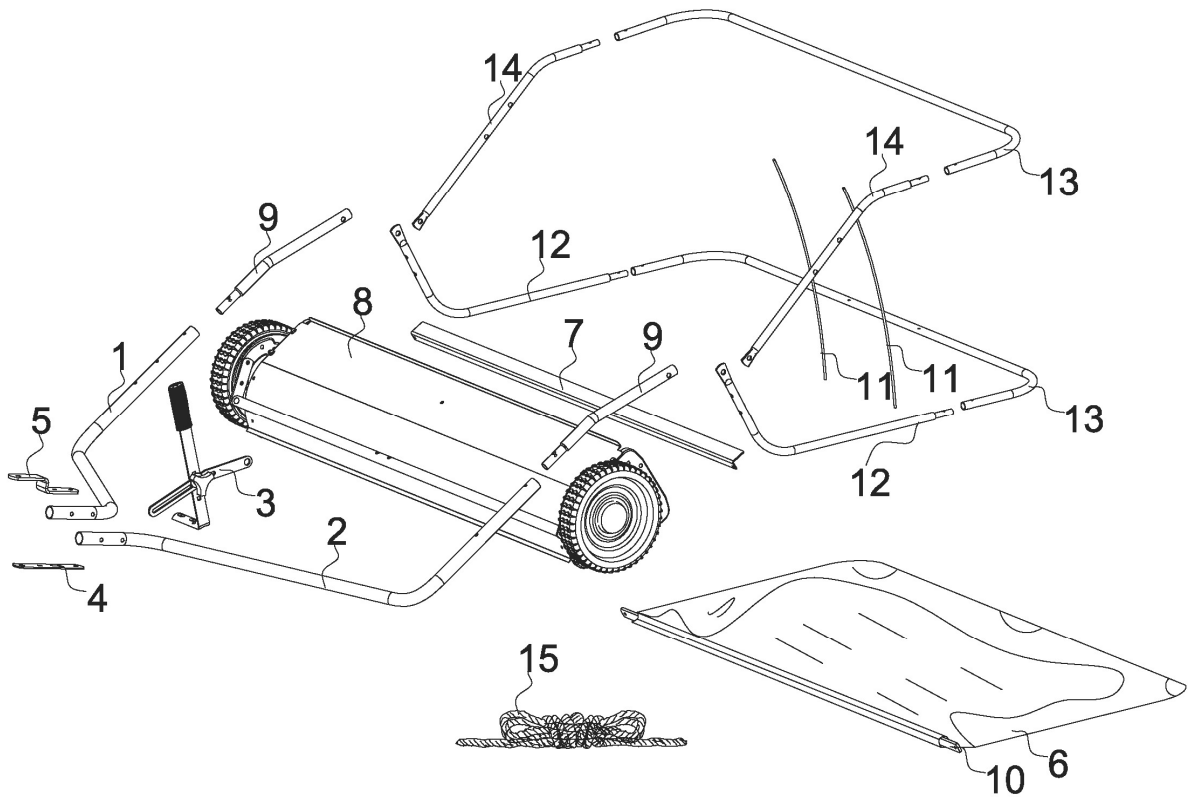

REF.	QTY.	DESCRIPTION	REF.	QTY.	DESCRIPTION
1	1	Hitch Tube (RH)	10	1	Bag Frame Strap
2	1	Hitch Tube (LH)	11	2	Hopper Support Rod
3	1	Handle Assembly	12	2	Lower Hopper Side Tube
4	1	Hitch Bracket (Straight)	13	2	Rear Hopper Tube
5	1	Hitch Bracket	14	2	Upper Hopper Side Tube
6	1	Hopper Bag	15	1	Rope
7	1	Connecting Rod			
8	1	Sweeper Housing Assembly			
9	2	Bag Arm Tube			

# Assembly Instructions

## Step 1: Mount Angle Bracket

A) Remove the three splints from brush.

B) Attach the Angle Bracket (K) to the sweeper housing by using the Hex Bolt M8x16 (F) and the Nylon Lock Nut M8 (G). Tighten securely.

**NOTE: Before tightening, make sure the angle bracket is aligned straight with the sweeper housing, as shown in the diagram.**

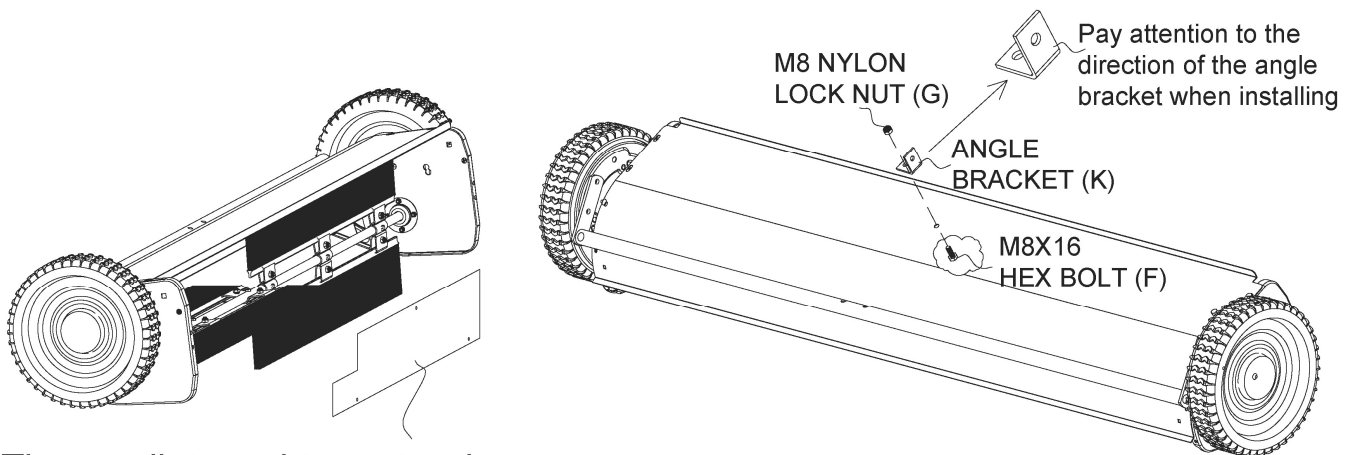

Three splint used to protect brush

**NOTE: Right Hand (RH) and Left Hand (LH) refer to the drivers' orientation when operating the vehicle.**

## STEP 2: Attach Hitch Tubes

Attach the right-hand (RH) and left-hand (LH) hitch tubes (parts 1 and 2) to the sweeper housing assembly (part 8) using Hex Bolts M6x40 (D) and Nylon Lock Nuts M6 (H). Tighten loosely.

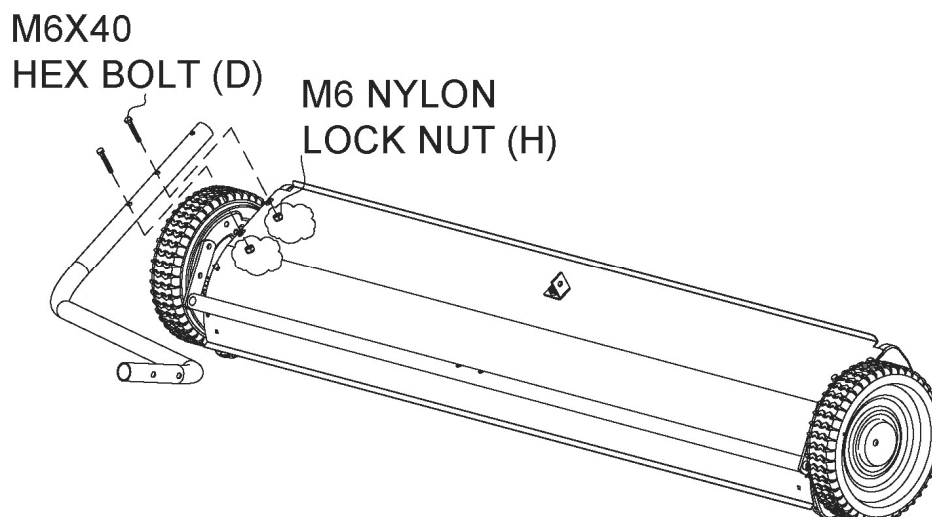

### STEP 3: Secure Hitch Tubes Together

Once the Hitch tubes are attached, pass two Hex Bolts M8x75 (A) through the hitch-end (away from the sweeper body) of the tubes to connect them together using two Nylon Lock Nuts M8 (G). Tighten loosely.

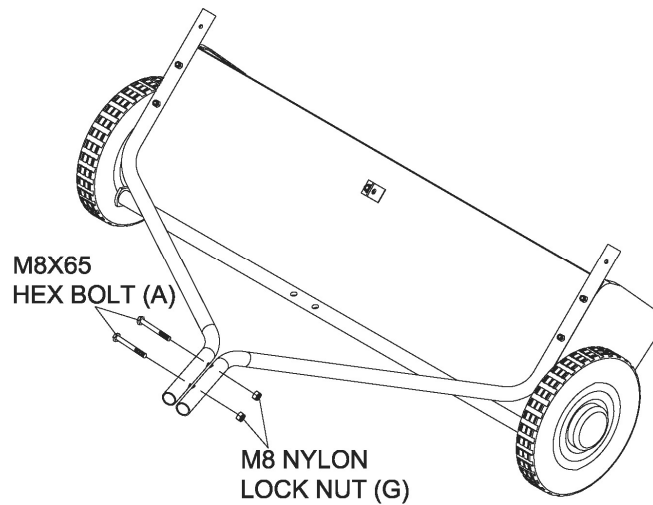

**NOTE:** If your vehicle's tow hitch is between 8" and 10", mount the angled hitch bracket on the bottom of the hitch tubes for best performance (See Figure B). For vehicles 11" and higher, see Figure A.

### STEP 4: Mount Hitch Assembly to Hitch Tubes

Attach the Hitch assembly in the following order: (see figure A)

- A) Mount the angled hitch bracket on top of the hitch tubes, with the straight hitch bracket on the bottom.
- B) Pass two hex bolts M8x50 (B) through the angled hitch bracket, premade notches in the hitch tubes, straight hitch bracket, and tighten loosely with two nuts M8 (G).
- C) Finally, pass the Hitch Pin (Y) through angled hitch bracket, Hitch Spacer (M), and straight hitch bracket, and fasten with R Pin Ø3 (N)

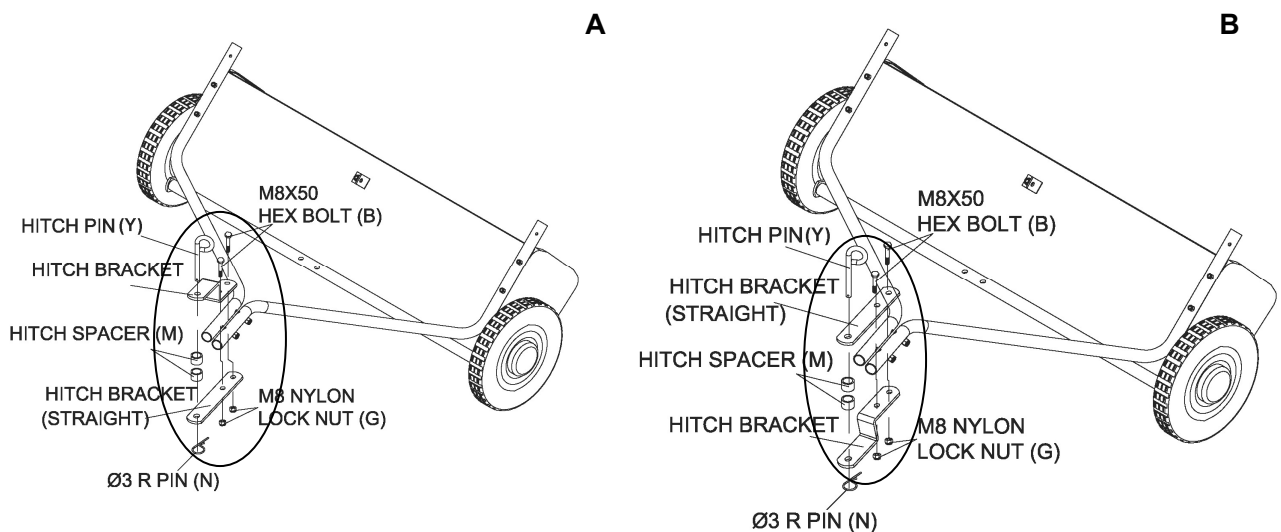

### STEP 5: Tighten all nuts and bolts from Steps 2 through 4.

## STEP 6: Attach Height Adjustment Handle

- A) Mount the height adjustment handle onto the height adjustment bar. (The height adjustment bar is located outside of the sweeper housing assembly, spanning the wheels.) Use two Hex Bolts M8x40 (C) and Nylon Lock Nuts M8 (G) to firmly attach the handle assembly to the bar.
- B) Attach the height adjustment strap to the angle bracket (mounted in Step 1). Align the round hole in the height adjustment strap with the angle bracket. In the following order, pass Hex Bolt M8x20 (E) through the angle bracket, the adjustable pole spacer (spacer bushing), the height adjustment strap, and the Big Flat Washer Ø8 (J). Tighten securely with Nylon Lock Nut M8 (G).

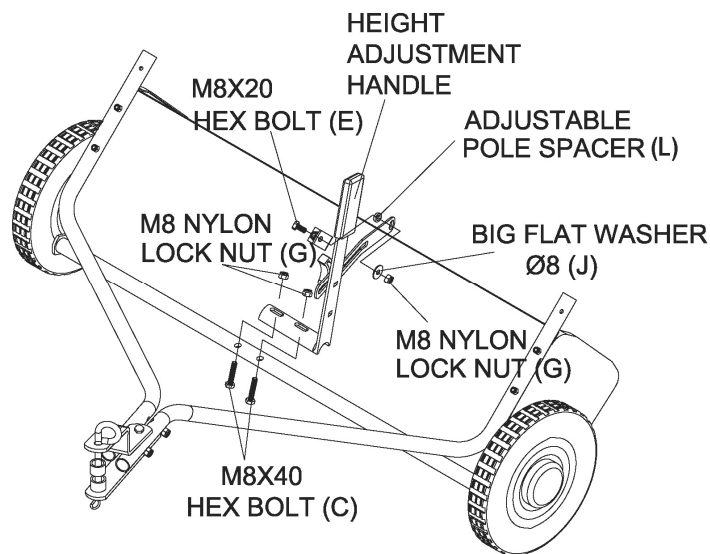

## STEP 7: Mount the Connecting Rod to the Sweeper Housing

- A) Mount the connecting rod using two Hex Bolts M6x12 (I) and Nylon Lock Nut M6 (H) to the upper most mounting holes of the sweeper housing. Tighten securely.

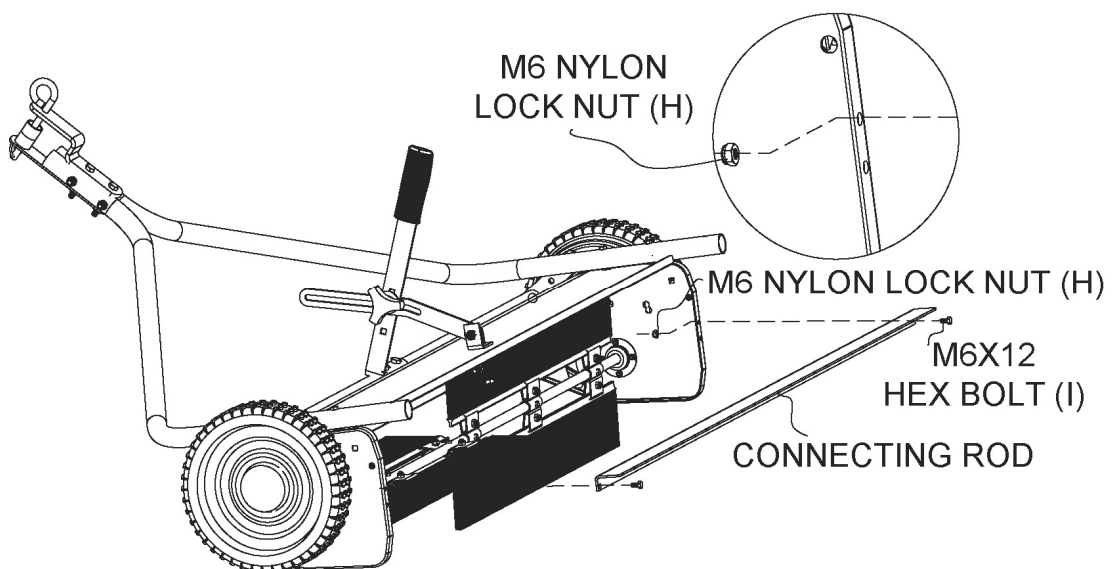

## STEP 8: Assemble Hopper Bag

- A) Unroll the hopper bag and place on the ground with the nylon fabric facing up and the heavy-duty nylon floor facing the ground.
- B) Inspect the first rear hopper tube (part 15) and locate the brace holes. Pass the tube through the six sewn-in bag loops at the top of the inside of the hopper bag with the brace holes facing downward.

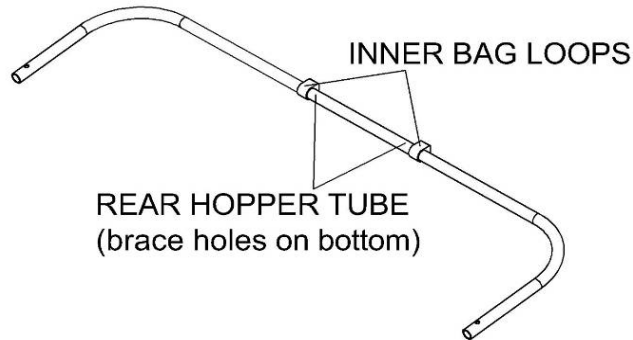

- C) Pass the upper hopper side tubes through the stitched sleeves on either side of the nylon fabric. On each side, insert the upper hopper side tube into the rear hopper tube, oriented downwards, and fasten plastic plugs (Z).

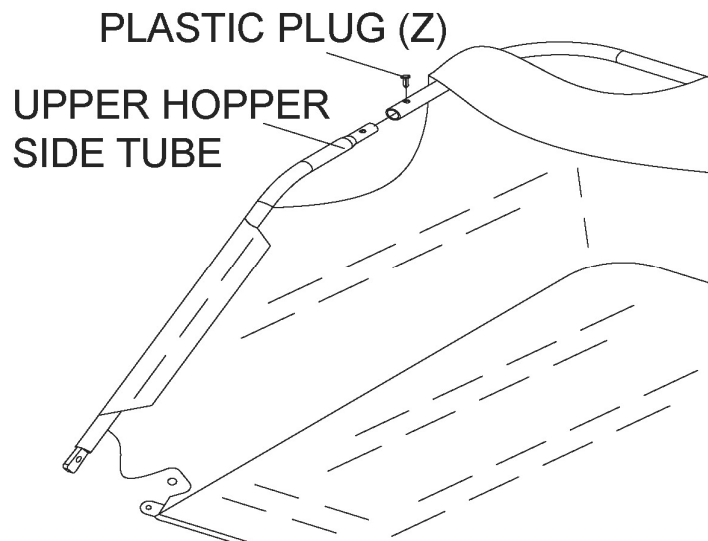

- D) Place the second rear hopper tube on the heavy-duty nylon floor of the hopper, with the brace holes facing upward.
- E) On each side, insert the lower hopper side tubes, oriented upwards, into the (lower) rear hopper tube, and fasten with plastic plugs (Z).

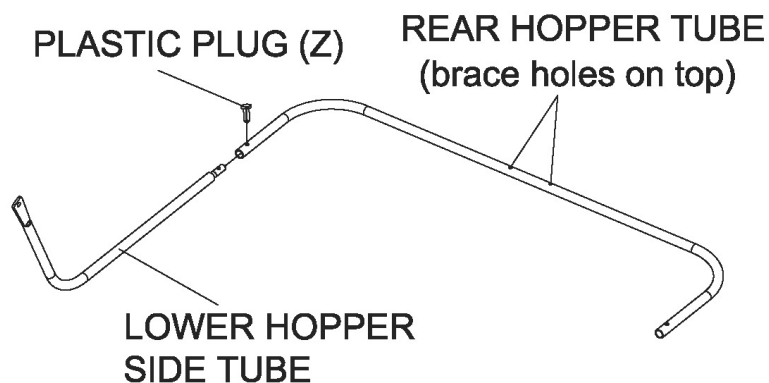

- F) On either side, align the ends of the upper and lower hopper side tubes and fasten these together with Clevis Pin  $\varnothing 9.5 \times 25$  (P). Secure with R Pin  $\varnothing 3$  (N).

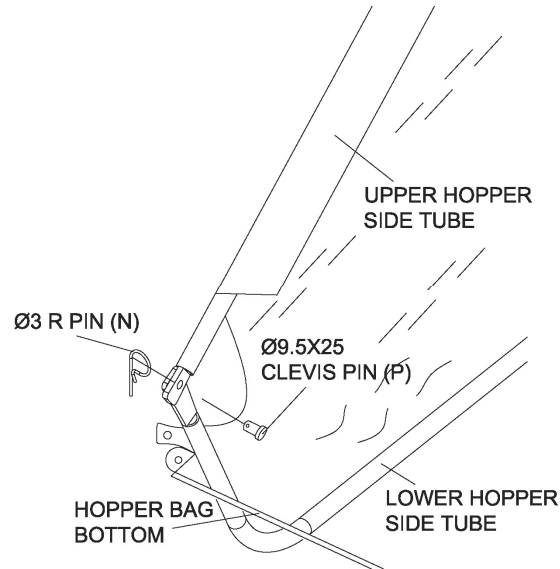

- G) Locate the stitched sleeve at the front edge of the bag floor. Insert the bag frame strap into the sleeve. (In some models, the bag frame strap is already inserted into the sleeve.)  
 H) Once inserted, mount the bag frame strap onto the lower hopper side tubes using Clevis Pins  $\varnothing 6 \times 37$  (Q). Secure with R Pin  $\varnothing 2$  (O).

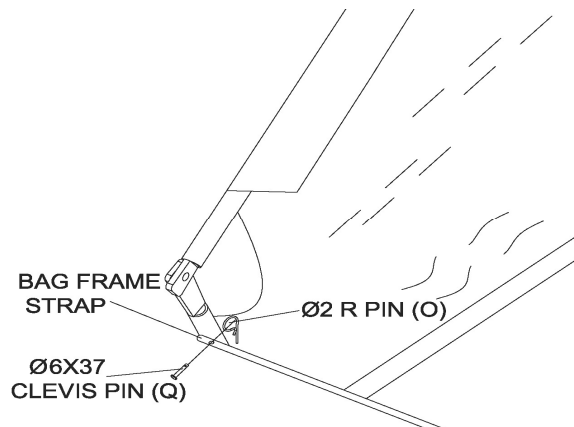

- I) Locate the snap buttons on the nylon fabric. Snap them into the rivets on the heavy-duty nylon floor of the hopper.

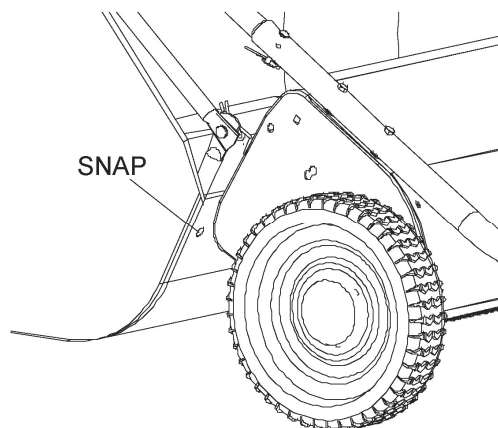

### CAUTION

Do not over-stress (bend) the support rods while installing. Over stressing causes the rods to bend and lose supporting tension.

- J) Insert the two hopper support rods into the brace holes in the upper and lower rear hopper tubes (part 15). The hopper assembly is now complete.

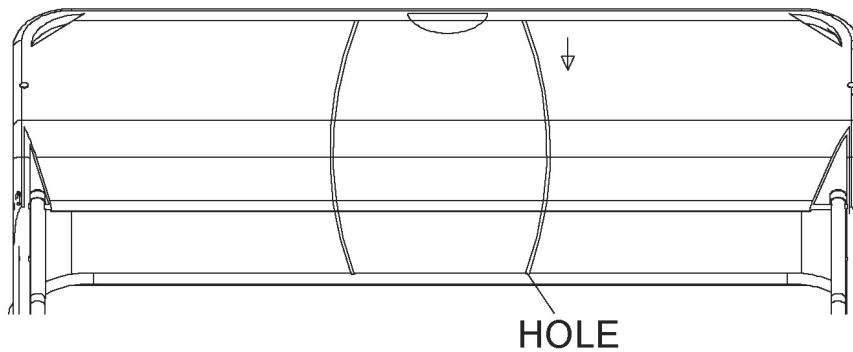

## STEP 9: Attach Hopper Bag to Sweeper

- A) There are two holes in the bar of each of the upper hopper side tubes. Locate the lower hole and pierce the nylon fabric at the location of the lower hole. **Note: some models have rivets in the fabric and do not require piercing the fabric.**

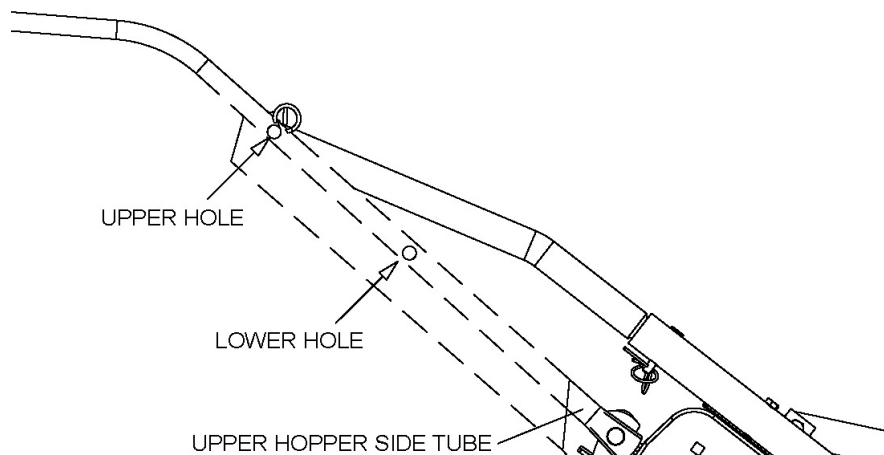

- B) On each side, mount a bag arm tube onto the upper hopper side tube using clevis pin  $\text{\O}8\text{X}59.5$  (R). Secure with R Pin  $\text{\O}3$  (N). Note the orientation of the bag arm tube: cap upward, male end facing down.

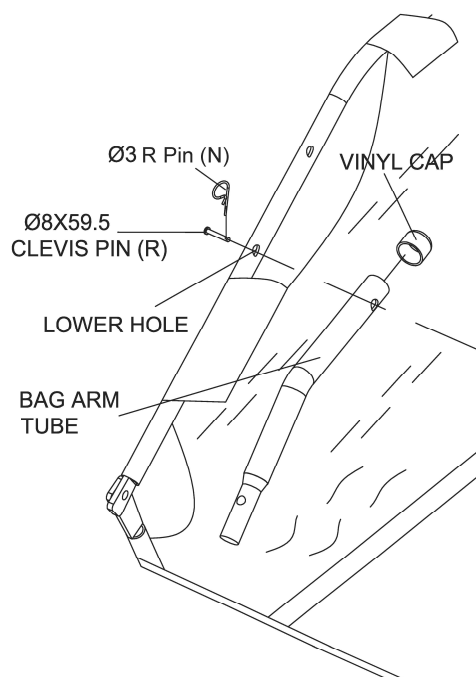

C) Tie the rope to the upper hopper tube at the center of the bag frame.

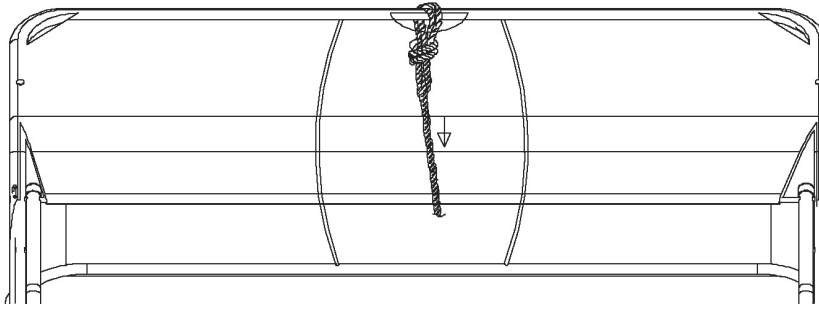

D) Insert the male ends of the bag arm tubes into the hitch tubes at the back of the sweeper housing assembly (away from the hitch). Secure using Clevis Pins  $\text{\O}6\text{X}37$  (Q) and R Pin  $\text{\O}2$  (O).

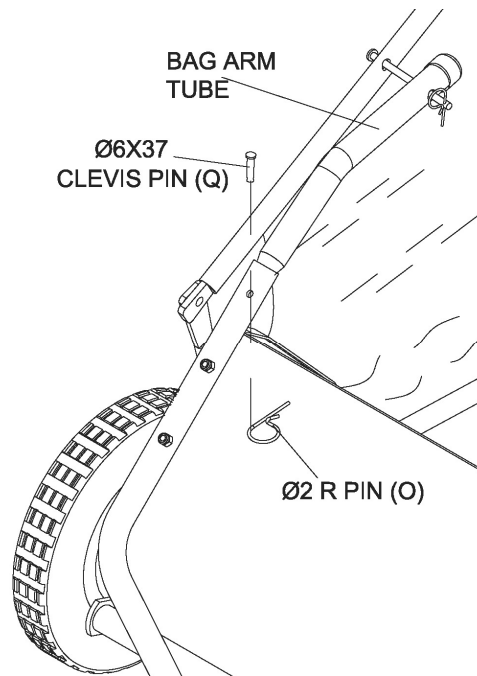

E) Remove brush protection boards from inside of sweeper housing assembly.

F) Check to see that all bolts are tightened adequately and all pins are mounted securely. If all the components are securely in place, the sweeper is completely assembled and ready for use.

# Operation Instructions

## WARNING

Before operating or using the sweeper, review the instructions below and safety information. Failure to follow these instructions may result in property damage or injury to the operator or bystanders.

### Attach the Sweeper to the Towing Vehicle

On a level surface, line up the towing vehicle with sweeper. Use the hitch pin and spacers to adjust the height of the tow hitch, as shown in the diagram. Once adjusted, insert the R Pin  $\varnothing 3$  to secure the hitch pin. For best results, the hopper should be level with the ground at a minimum clearance of 5". Secure the rope to the tow vehicle.

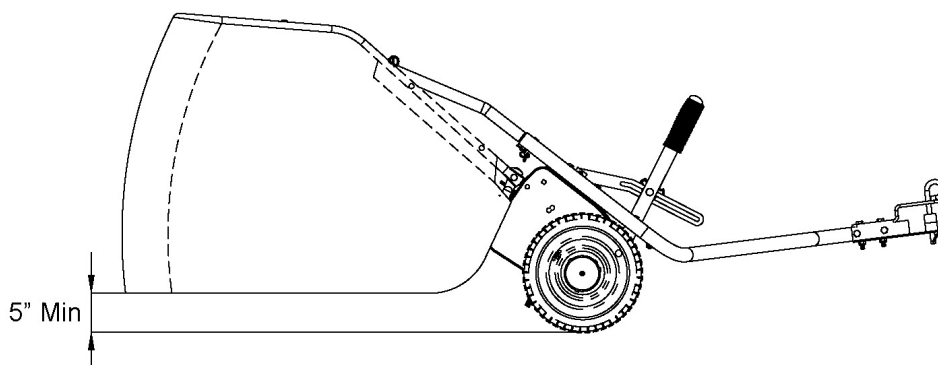
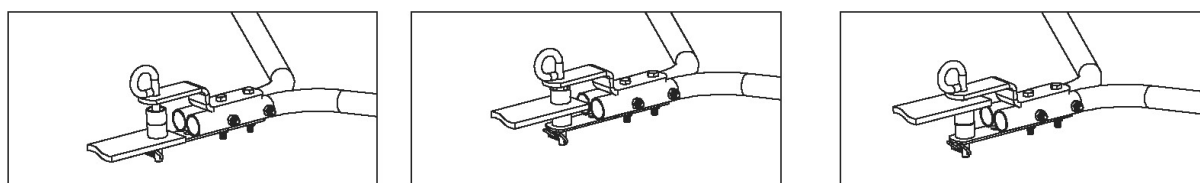

### Adjust the Height of the Brushes

Use the height adjustment handle to set the height of the brushes. For optimal results, the brush height should be  $\frac{1}{2}$ " below the tips of the grass. For sweeping other materials, you may need to adjust the height of the brushes.

### Towing the Sweeper

Your sweeper is designed to work at speeds of 5mph and lower. You may damage the device or experience sub-optimal results if exceeding 5mph. Your sweeper will work best on flat, smooth surfaces. If operating on a slope, always tow the sweeper up or down the surface of the hill, not sideways along the slope.

### Dumping the Hopper

When dumping the hopper, use the rope to pull the basket forward. Dump the hopper regularly for best performance.

## CAUTION

Always keep body parts clear from and clothing detached from the sweeper and rope. Keep sweeper away from fire or excessive heat will cause damage to the brushes and bag.

# Maintenance and Storage



## WARNING

Improper maintenance and storage of the sweeper may void your warranty.

## MAINTENANCE

- After each use clean material out of hopper.
- Rinse/dry inside and outside of the sweeper after each use.
- Periodically check all fasteners for tightness and replace any damaged fasteners.
- Check brushes for debris and keep brushes and brush shaft clean for optimal performance.
- Twice a year apply a few drops of light multipurpose oil to the brush shaft bearings.
- Annually clean and lightly lubricate all moving parts.
- Every two years remove and clean gears and apply an even coat of light synthetic grease.
- Use a glossy enamel spray paint to touch up scratched or worn painted metal surfaces.
- Never exceed the hopper load capacity rating it will damage the bag.
- Regularly grease axle and wheel bearing area or when needed.

## LUBRICATION

The bearings in the sweeper have been pre-lubricated at the factory; however, it is recommended that a few drops of light multipurpose oil should be added to the brush shaft bearings twice a year. Also, every two years the wheels should be removed to clean the gears. After cleaning the gears, apply an even coat of light synthetic grease.

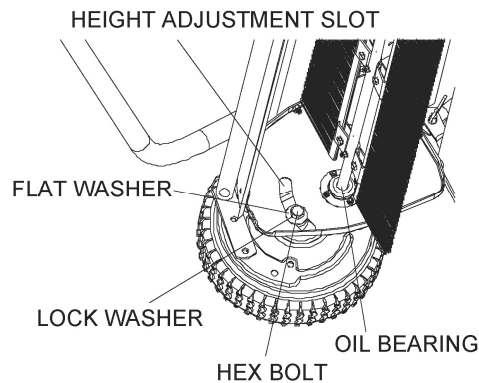

**NOTE:** To remove wheel, use a screwdriver to pop off hub cap, remove the lock nut and washer.

## WHEEL GEARS/PAWL SERVICE

**DO NOT** remove both wheels at the same time. Remove one wheel at a time to prevent mixing parts or using the wrong parts as the left and right wheels and parts are different. When removing gears, carefully note the position of all washers and other parts.

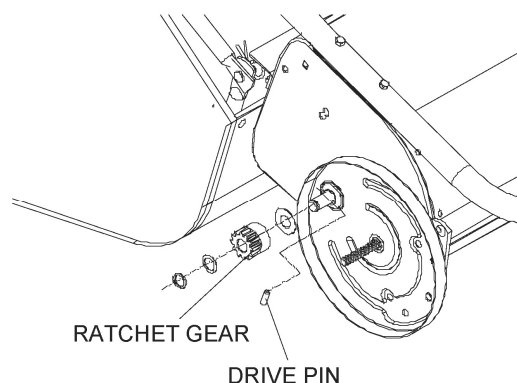

## BRUSH REPLACEMENT

1. Remove the hopper bag from lawn sweeper.
2. Only replace one brush at a time.
3. Tip the sweeper forward on housing. Do not remove the hex bolts from double brush retainers.
4. Loosen hex bolts and hex lock nuts from single brush retainers. Slide brush out of retainers, making note of over-lap bristles position.
5. Install new brush, make sure the over-lap bristles are in the same position as before replacement.

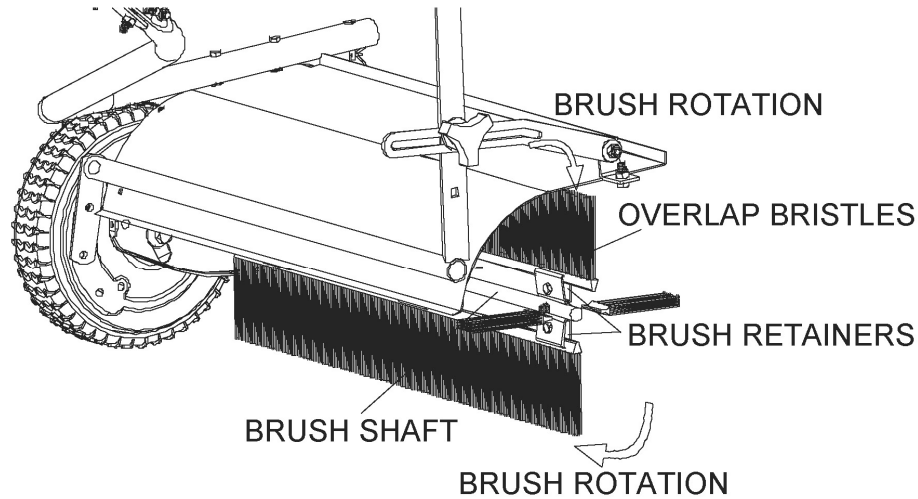

### **IMPORTANT:**

If a part needs replacement, only use parts that meet the manufacturer's specifications. Replacement parts that do not meet specifications may result in a safety hazard and/or poor operation.



### **WARNING**

Empty hopper bag before storage as full or partially full bags may pop/explode.

## STORAGE

- Be sure to completely empty, clean and dry the sweeper hopper bag before storage.
- Failure to properly clean the sweeper and hopper may cause deterioration such as rust or mold.
- Lightly lubricate all sweeper surfaces and moving parts to protect components and prevent rust.
- Store indoors or in a protected area during severe weather and winter months.
- Sweeper can be stored compactly:
  1. Pull the two bag arm tubes (#9) out of hitch tubes (#1 & #2).
  2. Remove the two hopper support rods (#11).
  3. Don't allow the brushes to contact the ground during storage to prevent damage.

# Specifications

Frame Construction.....	Steel
Hopper Construction.....	Nylon Mesh
Hitch Type.....	Pin Style
Wheel Type.....	Semi-Pneumatic
38" Lawn Sweeper Wheel Size.....	10"
42" Lawn Sweeper Wheel Size.....	10.5"

# Parts Drawing & Parts List

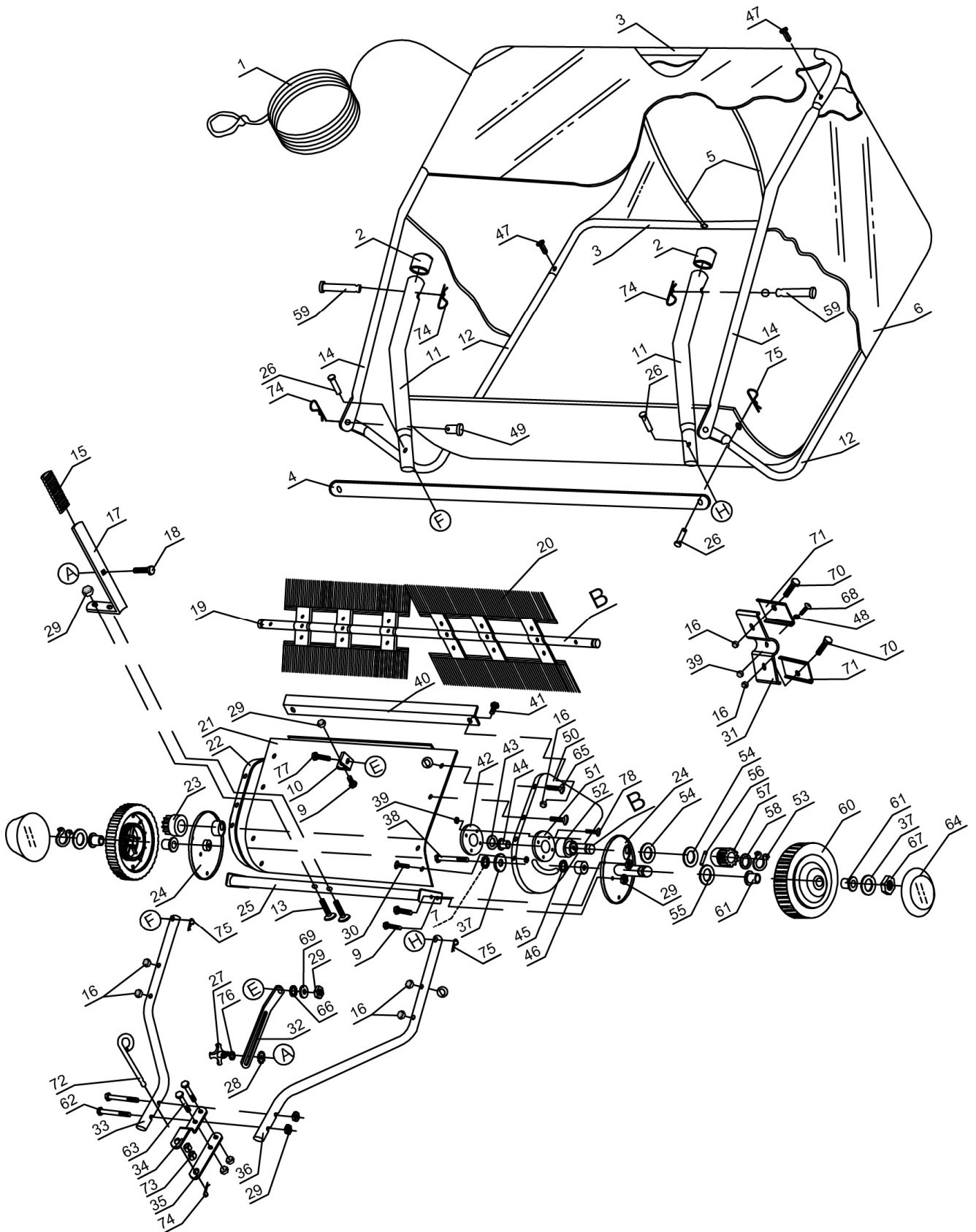

## Parts Drawing & Parts List

Ref#	Drawing No.	Description	Qty
1	N280-00038	Hopper Rope	1
2	N280-00009	Vinyl Cap	2
3	N280-00001-CD	Hopper Frame Tube (Rear)	2
4	N280-00015	Bag Frame Strap	1
5	N280-00005-DX	Hopper Support Rod	2
6	N280-00039	Hopper Bag	1
7	GB93/10/DX	Lock Washer Ø10	2
9	GB5781/M8×16/DX	Hex Bolt M8x16	5
10	N280-00014-DX	Angle Bracket	1
11	N280-00011	Bag Arm Tube	2
12	N280-00006-CD	Lower Hopper Frame Tube	2
13	GB5781/M8×40/DX	Hex Bolt M8x40	2
14	N280-00008-CD	Upper Hopper Frame Tube	2
15	N280-00004	Height Adjust Gripe	1
16	GB889/M6/DX	Nylon Lock Nut M6	18
17	N280-00020	Height Adjustment Handle	1
18	GB794/M8×30/DX	Carriage Bolt M8x30	1
19	N280-00027-DX	Brush Shaft	1
20	N280-31000	Brush	4
21	N280-00013	Wrapper	1
22	N280-10004	End Plate (R.H.)	1
23	N280-00012	Pinion Gear (R.H.)	1
24	N280-50000	Dust Cover Assembly	2
25	N280-40000	Height Adjustment Tube Assy	1
26	N280-00010-DX	Clevis Pin Ø6x37	4
27	N280-70000	Wing Knob	1
28	N28B-00003-DX	External teeth Washer	1
29	GB889/M8/DX	Nylon Lock Nut M8	12
30	GB818/M5×12/DX	Slotted Pan Head Screw M5x12	6
31	N280-30001-DX	Retainer Brush	6
32	N280-00019-DX	Height Adjustment Strap	1
33	N280-00023	Hitch Tube (R.H)	1
34	N100-00014	Hitch Bracket	1
35	N280-00025	Hitch Bracket (Straight)	1

Ref#	Drawing No.	Description	Qty
36	N280-00022	Hitch Tube (L.H.)	1
37	GB96/10/DX	Big Flat Washer Ø10	4
38	GB5781/M10×85/DX	Hex Bolt M10x85	2
39	GB889/M5/DX	Nylon Lock Nut M5	20
40	N280-00003-CD	Connecting Rod	1
41	GB5781/M6×12/DX	Hex Bolt M6x12	2
42	N280-10001-DX	Dust Cover Retainer	2
43	N280-00033-DX	Inside Star Washer	2
44	N280-10002	Brush Shaft Bushing	2
45	N280-00036-DX	Spacer Bushing	2
46	N280-00035-DX	Spacer for Axle	2
47	N280-00002	Plastic Bolt	4
48	GB862.1/5/FH	Star Washer Ø5	6
49	N280-00016-DX	Clevis Pin C	2
50	N280-60001	End Plate (L.H.)	1
51	N280-10003-DX	Special Washer	2
52	N280-00028-DX	Bushing	2
53	GB894/15/FH	Retaining Ring Ø15	2
54	N280-00029-FH	Adj. Washer A	4
55	N280-00043-FH	Adj. Washer C	2
56	9401-06020	Dowel Pin (Drive)	2
57	N280-00030	Pinion Gear (L.H.)	1
58	N280-00037-FH	Adj. Washer B	2
59	N280-00017-DX	Clevis Pin D	2
60	N280-20000	Wheel & Tire Assembly	2
61	N280-00034	Wheel Bushing	4
62	9101-08065-DX	Hex Bolt M8x65	2
63	9101-08050-DX	Hex Bolt M8x50	2
64	N280-00032	Hub Cap	2
65	9101-06040-DX	Hex Bolt M6x40	4
66	N28B-00001-DX	Spacer Bushing (Adjust Height)	1
67	9206-10000-DX	Nylon Lock Nut M10	2
68	9101-05025-DX	Hex Bolt M5x25	6
69	9302-08000-DX	Big Flat Washer Ø8	1

<b>Ref#</b>	<b>Drawing No.</b>	<b>Description</b>	<b>Qty</b>
70	9101-06020-DX	Hex Bolt M6x20	12
71	N280-30002-DX	Retainer Brush	12
72	N021-00003-DX	Hitch Pin	1
73	N280-00026-DX	Cotter Bushing	2
74	N280-00047-DX	R Pin Ø3	5
75	N280-00041-DX	R Pin Ø2	4
76	N280-00046-DX	Big Flat Washer	1
77	9101-08020-DX	Hex Bolt M8x20	1
78	GB818/M5x16/DX	Slotted Pan Head Screw M5x16	8

# Limited Warranty

## **Limited Warranty**

YTL International warrants that the product is free from defects in material and workmanship under normal use for one year. For one year from the date of purchase, if the original purchaser finds the product does not conform with this warranty, YTL International shall, at its exclusive option, either repair or replace the product (lawn sweeper).

YTL International shall have no obligation under the warranty set forth above if the original purchaser or other person: improperly assembles the product, misuses the product, overloads the product, operates or uses the product contrarily to instructions, or the product has been repaired or altered by anyone other than an authorized representative.

## **Limited Warranty Exclusions**

The limited warranty does not cover cosmetic defects, including, but not limited to, product paint and decals; nor does it cover items subject to ordinary wear from use of the product, including, but not limited to, tires. The warranty shall be voided by alteration of the product (except by YTL International), tampering with, improper installation or maintenance, accident or misuse. This warranty expressly excludes all damage to the product resulting from careless or neglectful handling or transportation once it has left YTL International's premises.

The product (lawn sweeper) requires consistent, periodic service for optimal performance and normal maintenance of the product is expressly excluded from the warranty. The warranty does not cover repair when normal use has exhausted the life of a part or the equipment as a whole. YTL International also does not warranty consumable supply-type items (such as oils/fluids, grease, etc.) sold with the product

The warranty will not apply to parts and/or labor if the product (lawn sweeper) has been misused, neglected, involved in an accident, abused, loaded beyond its limits, modified or assembled incorrectly.

## **Limits of Implied Warranty and Consequential Damage Exclusion**

YTL International disclaims any obligation to cover any loss of time, use of this product, freight, or any incidental or consequential claim by anyone from using this lawn sweeper. This warranty is given in place of all other warranties and assurances, whether express or implied, including but not limited to matters of quality, fitness for purpose or merchantability and the vendor accepts no liability, under any circumstances whatsoever, for any consequential damage of loss suffered by anyone as a result of using or being unable to use the product.

An exchanged/replaced product will be subject to the original limited warranty and warranty coverage will be calculated from the purchase date of the original product.

The warranty gives the consumer certain and specific legal rights which may vary from state to state. Your state may also have other rights you may be entitled to that are not listed within this warranty.

Please contact YTL International directly for warranty related questions and requests.

## **Contact Information**

YTL International  
17517 Fabrica Way, Suite H  
Cerritos, CA 90703  
Phone: (888) 723-6534  
Phone: (562) 404-8016  
Fax: (562) 404-8013  
E-mail: [parts@ytlinternational.com](mailto:parts@ytlinternational.com)  
Website: [www.ytlinternational.com](http://www.ytlinternational.com)