

# 250 OWNER'S MANUAL









# 1 MEANS OF REPRESENTATION

## 1.1 Symbols used

The meaning of specific symbols is described below

---

	indicates an expected reaction (e.g. of a work step or a function)
	Indicates an unexpected reaction (e.g. of a work step or a function)
	All work marked with this symbol requires specialist knowledge and technical understanding In the interest of your own safety, have these jobs performed by an authorized workshop. There, your motorcycle will be opt- mally cared for by specially trained experts using the specialist tools required
	Indicates a page reference (more information is provided on the specified page)
	Indicates information with more details or tips
	Indicates the result of a testing step

---

## 1.2 Formats used

The typographical formats used in this document are explained below.

---

<b>Specific name</b>	Identifies a proprietary name.
<b>Name</b>	Identifies a protected name.
<b>Brand</b>	Identifies a brand available on the open market.
<b>Underlined terms</b>	Refer to technical details of the vehicle or indicate technical terms that are explained in the glossary.

---

## 2 SAFETY ADVICE

### 2.1 Use definition- intended use

This vehicle is designed and built to withstand the normal stresses and strains of competitive use. This vehicle complies with the currently valid regulations and categories of the top international motorsport organizations



#### Info

Only operate this vehicle in closed-off areas remote from public road traffic.

### 2.2 Misuse

The vehicle must only be used as intended

Dangers can arise for people, property and the environment through use not as intended.

Any use of the vehicle beyond the intended and defined use constitutes misuse.

Misuse also includes the use of operating and auxiliary fluids which do not meet the required specification for the respective use.

### 2.3 Safety advice

A number of safety instructions need to be followed to operate the vehicle safely. Therefore, read this manual carefully. The safety instructions are highlighted in the text and are referred to at the relevant passages.



#### Info

The vehicle has various information and warning labels at prominent locations. Do not remove information/warning labels. If they are missing, you or others may not recognize dangers and may therefore be injured.

### 2.4 Degrees of risk and symbols



#### Danger

Indicates a danger that will immediately and invariably lead to fatal or serious permanent injury if the appropriate measures are not taken.



#### Warning

Indicates a danger that is likely to lead to fatal or serious injury if the appropriate measures are not taken.



#### Caution

Indicates a danger that may lead to minor injuries if the appropriate measures are not taken.

#### Note

Indicates a danger that will lead to considerable machine and material damage if the appropriate measures are not taken.



#### Warning

Indicates a danger that will lead to environmental damage if the appropriate measures are not taken.

### 2.5 Tampering warning

Tampering with the noise control system is prohibited. Federal law prohibits the following acts or the causing thereof

1 The removal or rendering inoperative by any person other than for purposes of maintenance, repair, or replacement, of any device or element of design incorporated into any new vehicle for the purpose of noise control prior to its sale or delivery to the ultimate purchaser or while it is in use, or

2 the use of the vehicle after such device or element of design has been removed or rendered inoperative by any person.

Among those acts presumed to constitute tampering are the acts listed below:

1 Removal or puncturing of the main silencer, baffles, header pipes or any other components which conduct exhaust gases.

2 Removal or puncturing of parts of the intake system.

3 Lack of proper maintenance.

4 Replacing moving part of the vehicle, or parts of the exhaust or intake system, with parts other than those specified by the manufacturer.

## 2.6 Safe operation



### Danger

**Danger of accidents** A rider who is not fit to ride poses a danger to him or herself and others.

- Do not operate the vehicle if you are not fit to ride due to alcohol, drugs or medication
- Do not operate the vehicle if you are physically or mentally impaired.



### Danger

**Danger of poisoning** Exhaust gases are toxic and inhaling them may result in unconsciousness and death.

- Always make sure there is sufficient ventilation when running the engine
- Use an effective exhaust extraction system when starting or running the engine in an enclosed space



### Warning

**Danger of burns** Some vehicle components become very hot when the vehicle is operated.

- Do not touch any parts such as the exhaust system, radiator, engine, shock absorber, or brake system before the vehicle parts have cooled down.
- Let the vehicle parts cool down before you perform any work on the vehicle.

Only operate the vehicle when it is in perfect technical condition, in accordance with its intended use, and in a safe and environmentally compatible manner.

The vehicle should only be used by trained persons.

Have malfunctions that impair safety promptly eliminated by an authorized workshop.

Adhere to the information and warning labels on the vehicle.

## 2.7 Protective clothing



### Warning

**Risk of injury** Missing or poor protective clothing presents an increased safety risk.

- Wear appropriate protective clothing such as helmet, boots, gloves as well as trousers and a jacket with protectors on all sides.
- Always wear protective clothing that is in good condition and meets the legal regulations.

In the interest of your own safety, recommends that you only operate the vehicle while wearing protective clothing

## 2.8 Work rules

Special tools are necessary for certain tasks. The tools are not contained in the vehicle but can be ordered under the number in parentheses. E.g: bearing puller(15112017000)

During assembly, non-reusable parts(e.g self-locking screws and nuts, seals and seal rings,O-rings,pins,lock washers)must be replaced by new parts.

In some instances a thread locker is required.The manufacturer instructions for use must be followed.

After disassembly, clean the parts that are to be reused and check them for damage and wear. Change damaged or worn parts. After you complete the repair or service work, check the operating safety of the vehicle

## 2.9 Environment

If you use your motorcycle responsibly, you can ensure that problems and conflicts do not occur. To protect the future of the motorcycle sport, make sure that you use your motorcycle legally, display environmental consciousness, and respect the rights of others. When disposing of used oil, other operating and auxiliary fluids, and used components, comply with the laws and regulations of your respective country.

Because motorcycles are not subject to the EU regulations governing the disposal of used vehicles, there are no legal regulations that pertain to the disposal of an end-of-life motorcycle. Your authorized dealer will be glad to advise you.

## 2 SAFETY ADVICE

### 2.10 Owner's Manual

It is important that you read this Owner's Manual carefully and completely before making your first trip. The Owner's Manual contains useful information and many tips on how to operate, handle, and maintain your motorcycle. Only then will you find out how to customize the vehicle ideally for your own use and how you can protect yourself from injury.

Keep the Owner's Manual in an accessible place to enable you to refer to it as needed.

If you would like to know more about the vehicle or have questions on the material you read, please contact an authorized dealer. The Owner's Manual is an important component of the vehicle and must be handed over to the new owner if the vehicle is sold.

## 3 IMPORTANT NOTES

### 3.1 Manufacturer and implied warranty

The work specified in the service schedule may only be performed in an authorized workshop and must be recorded in both the Service & Warranty Booklet and in [www.zuumavmoto.com](http://www.zuumavmoto.com), otherwise any warranty coverage will become void. Damage or secondary damage caused by tampering with and/or conversions on the vehicle are not covered by the warranty. Additional information on the manufacturer or implied warranty and the procedures involved can be found in the Service B Warranty Booklet.

### 3.2 Operating and auxiliary substances



#### Warning

**Environmental hazard** Improper handling of fuel is a danger to the environment.

- Do not allow fuel to enter the groundwater, the soil or the sewage system.

Use operating and auxiliary substances (such as fuel and lubricants) as specified in the Owner's Manual.

### 3.3 Spare parts, accessories

For your own safety, only use spare parts and accessory products that are approved and/or recommended by and have them installed by an authorized workshop. We accept no liability for other products and any resulting damage or loss.

Certain spare parts and accessory products are specified in parentheses in the descriptions. Your authorized dealer will be glad to advise you.

The current **Power Parts** for your vehicle can be found on the website.

International Website <http://www.zuumavmoto.com>.

### 3.4 Service

A prerequisite for perfect operation and prevention of premature wear is that the service, care, and tuning work on the engine and chassis is properly carried out as described in the Owner's Manual. Incorrect adjustment and tuning of the engine and chassis can lead to damage and breakage of components.

Use of the vehicle under difficult conditions, such as on sand or on wet and muddy surfaces, can lead to considerably more rapid wear of components such as the drive train, brake system, or suspension components. For this reason, it may be necessary to inspect or replace parts before the next scheduled service.

It is imperative that you adhere to the stipulated run-in times and service intervals. If you observe these exactly, you will ensure a much longer service life for your motorcycle.

### 3.5 Figures

The figures contained in the manual may depict special equipment.

In the interest of clarity, some components may be shown disassembled or may not be shown at all. It is not always necessary to disassemble the component to perform the activity in question. Please follow the instructions in the text.

### 3.6 Customer service

Your authorized dealer will be happy to answer any questions you may have on your vehicle and

A list of authorized dealers can be found on the website.

International Website <http://www.zuumavmoto.com>.

## 4 VIEW OFVEHICLE

### 4 . 1 View of vehicle, front left( example)



1	Hand brakelever
2	start Switch
3	Clutch lever
4	Air filter box cover
5	Plug-in stand
6	Shift lever
7	Choke
8	Fuel tap

## 4 VIEW OFVEHICLE

### 4.2 View of vehicle, rear right(example)



1	Seat
2	Filler cap
3	Throttle grip
4	Kick starter
5	Foot brake lever
6	Shock absorber compression adjustment
7	Level viewer for brake fluid, rear
8	Shock absorber rebound adjustment

## 5 SERIAL NUMBERS

### 5 . 1 Chassis number

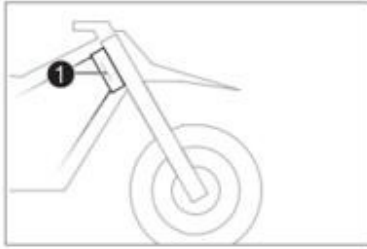

The chassis number 1 is stamped on the right side of the steering head

### 5.2 Type label

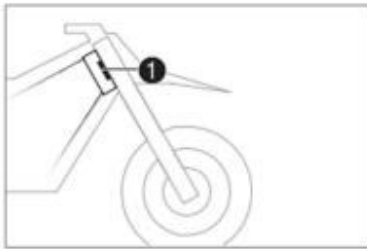

The type label 1 is fixed to the front of the steering head.

### 5 . 3 Engine number

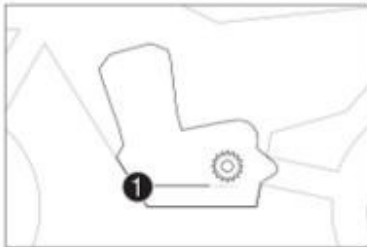

The engine number 1 is stamped on the left side of the engine under the engine sprocket

## 6 CONTROLS

### 6.1 Clutch lever

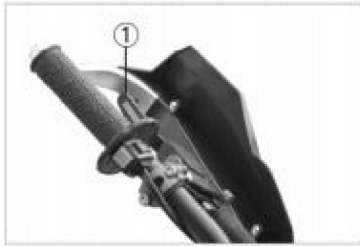

Clutch lever **1** is fitted on the handlebar on the left  
The clutch is activated hydraulically and adjusts itself automatically .

### 6.2 Hand brake lever

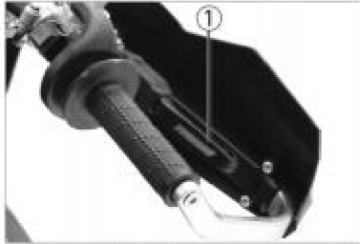

Hand brake lever **1** is fitted on the right side of the handlebar.  
The front brake is engaged using the hand brake lever

### 6.3 Throttle grip

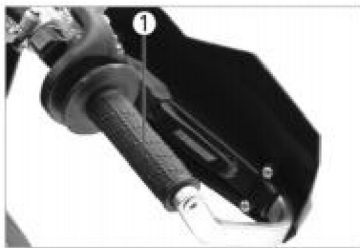

Throttle grip **1** is fitted on the right side of the handlebar

### 6.4 Kill switch



The kill switch **1** is fitted on the left side of the handlebar

#### **Possible states**

- Kill switch in basic position- In this position, the ignition circuit is closed, and the engine can be started.
- Kill switch pressed- In this position, the ignition circuit is interrupted a running engine stops, and a non-running engine will not start

### 6 . 5 Opening the filler cap



#### **Danger**

**Fire hazard** Fuel is highly flammable.

The fuel in the fuel tank expands when warm and can escape if overfilled.

- Do not refuel the vehicle in the vicinity of open flames or lit cigarettes.
  - Switch off the engine for refueling .
- Make sure that no fuel is spilled; particularly not on hot parts of the vehicle .
- If any fuel is spilled, wipe it off immediately .
  - Observe the specifications for refueling

**Warning**  
**Danger of poisoning** Fuel is poisonous and a health hazard

- Avoid skin, eye and clothing contact with fuel.
- Immediately consult a doctor if you swallow fuel.
- Do not inhale fuel vapors.
- In case of skin contact, rinse the affected area with plenty of water
- Rinse the eyes thoroughly with water, and consult a doctor in case of fuel contact with the eyes
- Change your clothing in case of fuel spills on them.
- Keep fuels correctly in a suitable canister, and out of the reach of children

**Warning**  
**Environmental hazard** Improper handling of fuel is a danger to the environment

- Do not allow fuel to enter the groundwater, the soil, or the sewage system.



Turn filler cap 1 counterclockwise and lift it off.

**6.6 Closing the filler cap**

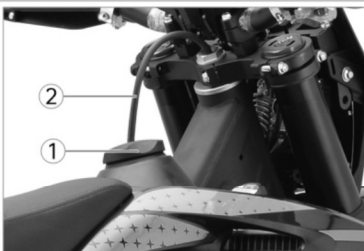

- Mount filler cap 1 and turn it clockwise until the fuel tank is tightly closed

**i Info**

Run the fuel tank breather hose 2 without kinks.

**6.7 Fuel tap**

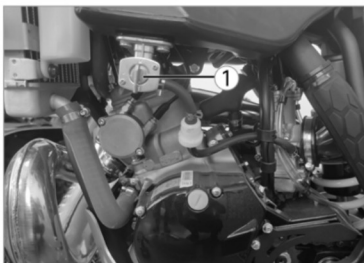

Fuel tap 1 is on the left of the fuel tank.

Open or close the supply of fuel to the carburetor using tap handle 1 on the fuel tap.

**Possible states**

- Fuel supply closed **OFF** - Fuel cannot flow from the fuel tank to the carburetor
- Fuel supply open **ON** - Fuel can flow from the fuel tank to the carburetor. The fuel tank empties completely.

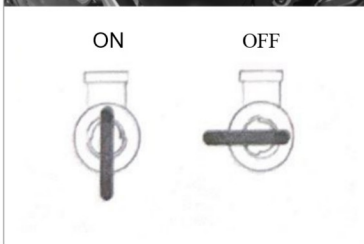

## 6 CONTROLS

### 6.8 Choke

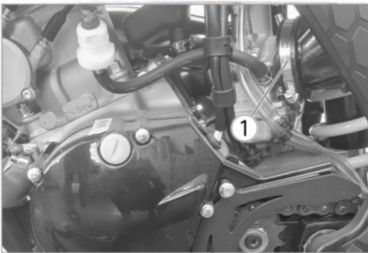

Choke 1 is fitted on the left side of the carburetor. Activating the choke function frees a drill hole in the carburetor through which the Engine can draw extra fuel. This results in a richer fuel-air mixture, which is needed for a cold start.

#### **i** Info

If the engine is warm, the choke function must be deactivated.

#### **Possible states**

- Choke function activated - The choke lever is pulled out to the stop.
- Choke function deactivated - The choke lever is pushed in to the stop.

### 6.9 Shift lever

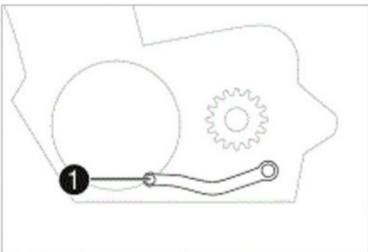

Shift lever 1 is mounted on the left of the engine.

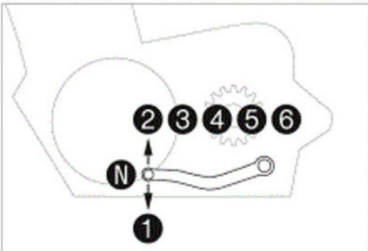

The gear positions can be seen in the photograph. The neutral or idle position is between the first and second gears.

### 6.10 Kick starter

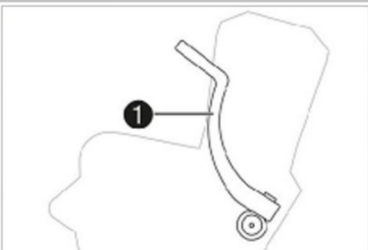

Kick starter 1 is fitted on the right side of the engine. The top part of the kick starter pivots.

#### **i** Info

Before riding, swing the top part of the kick starter inward toward the engine.

### 6.11 Foot brake lever

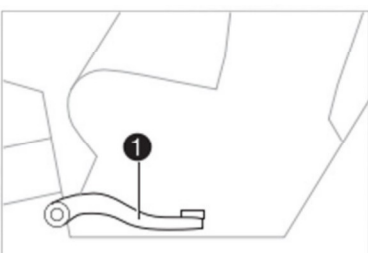

Foot brake lever 1 is located in front of the right footrest. The foot brake lever is used to activate the rear brake.

## 6 CONTROLS

### 6 . 12 Plug-in stand

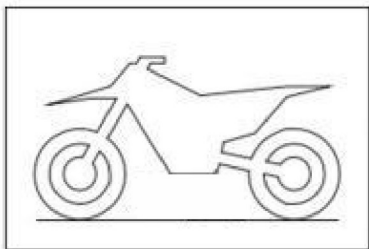

The holder for plug-in stand **1** is on the left side of the wheel spindle  
The plug-in stand is used to park the motorcycle.

**i Info**

Remove the plug-in stand before riding.

### 6 . 13 Service hour counter



The service hour counter **1** is fitted in front of the handlebar  
It shows the total number of service hours of the engine .  
The service hour counter begins counting when the engine is started and stops when the engine is switched off.

**i Info**

It is not possible to delete or adjust anything on the service hour counter

## 7 PREPARING FOR USE

### 7.1 Advice on first use



#### **Danger**

**Danger of accidents** A rider who is not fit to ride poses a danger to him or herself and others.

Do not operate the vehicle if you are not fit to ride due to alcohol, drugs or medication.

Do not operate the vehicle if you are physically or mentally impaired.



#### **Warning**

**Risk of injury** Missing or poor protective clothing presents an increased safety risk.

Wear appropriate protective clothing such as helmet, boots, gloves as well as trousers and a jacket with protectors on all ride.

Always wear protective clothing that is in good condition and meets the legal regulations.



#### **Warning**

**Danger of crashing** Different tire tread patterns on the front and rear wheel impair the handling characteristic.

Different tire tread patterns can make the vehicle significantly more difficult to control.

Make sure that only tires with a similar tire tread pattern are fitted to the front and rear wheel.



#### **Warning**

**Danger of accidents** An unadapted riding style impairs the handling characteristic.

Adapt your riding speed to the road conditions and your riding ability.



#### **Warning**

**Danger of accidents** The vehicle is not designed to carry passengers.

Do not ride with a passenger.



#### **Warning**

**Danger of accidents** The brake system fails in the event of overheating.

If the foot brake lever is not released, the brake linings drag continuously.

Take your foot off the foot brake lever when you are not braking.



#### **Warning**

**Danger of accidents** Total weight and axle loads influence the handling characteristic.

Do not exceed the maximum permissible overall weight or the axle loads.



#### **Warning**

**Risk of misappropriation** People who act without authorization endanger themselves and others.

Do not leave the vehicle unattended if the engine is running.

Protect the vehicle against access by unauthorized persons.



#### **Info**

When using your motorcycle, remember that others may feel disturbed by excessive noise.

Make sure that the pre-delivery inspection work has been carried out by an authorized workshop.

You receive a delivery certificate and the Service and Warranty Booklet at vehicle handover.

Before your first trip, read the entire Owner's Manual carefully.

Get to know the controls.

Adjust the basic position of clutch lever.

Adjust the basic position of the hand brake lever.

Adjust the basic position of the foot brake lever. x

Adjust the basic position of the shift lever.

Get used to handling the motorcycle on a suitable surface before undertaking a more challenging trip.



#### **Info**

Your motorcycle is not approved for use on public roads.

When off road, it is recommended that you are accompanied by another person on another vehicle so that you can help each other.

## 7 PREPARING FOR USE

Try also to ride as slowly as possible and in a standing position to get a better feeling for the motorcycle.

Do not make any off-road trips that exceed your ability and experience.

Hold the handlebar firmly with both hands and keep your feet on the footrests when riding

Do not take luggage along.

Do not exceed the maximum permissible weight and the maximum permissible axle loads

Guideline

Maximum permissible overall weight	335 kg(739 lb.)
Maximum permissible front axle load	145 kg(320 lb.)
Maximum permissible rear axle load	190 kg(419 lb.)

Check the spoke tension .



### Info

The spoke tension must be checked after half an hour of operation.

Run in the engine . ( p . 17)

## 7.2 Running in the engine

During the running-in phase, do not exceed the specified engine performance.

Guideline

Maximum engine performance	
During the first 3 operating hours	< 70 %
During the first 5 operating hours	< 100 %

Avoid fully opening the throttle!

## 7.3 Preparing the vehicle for difficult riding conditions



### Info

Use of the vehicle under difficult conditions, such as on sand or on wet and muddy surfaces, can lead to considerably more rapid wear of components such as the drive train, brake system, or suspension components. For this reason, it may be necessary to inspect or replace parts before the next scheduled service.

Seal the air filter box

Secure the air filter box cover . 4

Clean the air filter and air filter box .4



### Info

Check the air filter approx. every 30 minutes.

Check the electrical connector for humidity and corrosion and to ensure it is firmly seated.

If humidity, corrosion, or damage is found,

Clean and dry the connector, or change it if necessary

**Difficult riding conditions are:**

Rides on dry sand .

Rides on wet sand .

Rides on wet and muddy surfaces.

Riding at high temperatures and low speeds.

Rides at low temperature or in snow.

## 7 PREPARING FOR USE

### 7.4 Preparing for rides on dry sand



Check the radiator cap

Value on the radiator cap	1.1 bar
---------------------------	---------

If the indicated value does not correspond to the required value



#### Warning

**Danger of scalding** During motorcycle operation, the coolant gets very hot and is under pressure.

- Do not open the radiator, the radiator hoses or other cooling system components if the engine or the cooling system are at operating temperature.

Allow the cooling system and the engine to cool down before you open the radiator, the radiator hoses or other components of the cooling system.

In the event of scalding, rinse the area affected immediately with lukewarm water.

- Change the radiator cap

Fit a dust cover on the air filter.

Dust cover for air filter
---------------------------



#### Info

See the **Power Parts** fitting instructions.



Fit a sand cover on the air filter.

Sand cover for air filter
---------------------------



#### Info

See the **Power Parts** fitting instructions.



#### Info

Your authorized workshop can recommend the right carburetor tuning.



Clean the chain.

Chain cleaner
---------------

Fit the steel sprocket



#### Tip

Do not grease the chain

Clean the radiator fins.

Straighten bent radiator fins carefully

#### Condition

Regular use in sand

## 7 PREPARING FOR USE

Change the piston every 10 operating hours .

### 7 . 5 Preparing for rides on wet sand



Check the radiator cap

Value on the radiator cap

1.1 bar

If the indicated value does not correspond to the required value .



#### Warning

**Danger of scalding** During motorcycle operation, the coolant gets very hot and is under pressure.

Do not open the radiator, the radiator hoses or other cooling system components if the engine or the cooling system are at operating temperature.

Allow the cooling system and the engine to cool down before you open the radiator, the radiator hoses or other components of the cooling system.

In the event of scalding, rise the area affected immediately with lukewarm water.

Change the radiator cap.

Fit a waterproofing device on the air filter

Waterproofing device for air filter



#### Info

See the **Power Parts** fitting instructions.



#### Info

Your authorized workshop can recommend the right carburetor tuning



Clean the chain.

Chain cleaner

Fit the steel sprocket.



#### Tip

Do not grease the chain

Clean the radiator fins.

Straighten bent radiator fins carefully

#### Condition

Regular use in sand

Change the piston every 10 operating hours.

## 7.6 Preparing for rides on wet and muddy surfaces

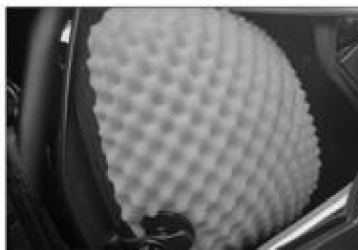

Fit a waterproofing device on the air filter.

Waterproofing device for air filter

**Info**

See the **Power Parts** fitting instructions.

**Info**

Your authorized workshop can recommend the right carburetor tuning



Fit the steel sprocket

Clean the motorcycle.

Straighten bent radiator fins carefully

## 7.7 Preparations for riding at high temperatures and low speeds



Check the radiator cap

Value on the radiator cap

1.1 bar

If the displayed value does not equal the set point value:

**Warning**

**Danger of scalding** During motorcycle operation, the coolant gets very hot and is under pressure.

Do not open the radiator, the radiator hoses or other cooling system components if the engine or the cooling system are at operating temperature.

Allow the cooling system and the engine to cool down before you open the radiator, the radiator hoses or other components of the cooling system

In the event of scalding, rinse the area affected immediately with lukewarm water.

Change the radiator cap

Adjust the secondary ratio to the terrain

**Info**

The engine oil heats up quickly when the clutch is operated frequently due to an excessively high secondary drive.



Clean the chain

Chain cleaner

Clean the radiator fins

## 7 PREPARING FOR USE

Carefully align bent radiator fins.  
Check the coolant level.

### 7 . 8 Preparing for rides at low temperature or in snow

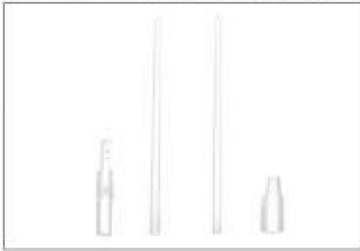

Fit a waterproofing device on the air filter.

Waterproofing device for air filter



#### Info

See the **Power Parts** fitting instructions.



#### Info

Your authorized workshop can recommend the right carburetor tuning

## 8 RIDING INSTRUCTIONS

### 8.1 Checks and maintenance measures when preparing for use

**i Info**  
Before every trip, check the condition of the vehicle and ensure that it is safe to operate  
The vehicle must be in perfect technical condition when it is being operated.

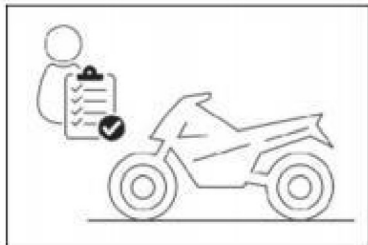

Check the gear oil level  
Check the front brake fluid level.  
Check the rear brake fluid level.  
Check the front brake linings.  
Check the rear brake linings.  
Check that the brake system is functioning properly.  
Check the coolant level.  
Check the chain for dirt.  
Check the chain, rear sprocket, engine sprocket, and chain guide.  
Check the chain tension .  
Check the tire condition.  
Check the tire air pressure.  
Check the spoke tension.

**i Info**  
The spoke tension must be checked regularly as incorrect spoke tension will strongly impair riding safely

Clean the dust boots of the fork legs.  
Bleed the fork legs .  
Check the air filter.  
Check the settings of all controls and ensure that they can be operated smoothly  
Check all screws, nuts, and hose clamps regularly for tightness  
Check the fuel level

### 8.2 Starting

**⚠ Danger**  
**Danger of poisoning** Exhaust gases are toxic and inhaling them may result in unconsciousness and death  
Always make sure there is sufficient ventilation when running the engine.  
- Use an effective exhaust extraction system when starting or running the engine in an enclosed space.

**Note**  
**Engine damage** High revving speed with a cold engine negatively impacts the lifespan of the engine.  
Always run the engine warm at a low speed

**i Info**  
If the motorcycle is unwilling to start, the cause can be old fuel in the float chamber. The flammable elements of the fuel evaporate after a long time of standing  
If the float chamber is filled with fresh fuel, the engine starts immediately.

#### **The motorcycle has been out of use for more than 1 week**

Empty the carburetor float chamber.  
Turn handle 1 of the fuel tap to the ON position.  
Fuel can flow from the fuel tank to the carburetor  
- Remove the plug-in stand.  
Shift the transmission to idle

**Condition**  
The engine is cold

## 8 RIDING INSTRUCTIONS

Pull the choke lever out as far as possible  
Press the kick starter robustly through its full range

### Info

 Do not open the throttle.

### 8.3 Starting off

#### Info

 The plug-in stand must be removed before riding.  
While riding, the side stand must be folded up and secured with the rubber band.

Pull the clutch lever, shift into first gear, release the clutch lever slowly and at the same time open the throttle gently.

### 8.4 Shifting, riding



#### Warning

**Danger of accidents** If you change down at high engine speed, the rear wheel blocks and the engine racos.  
Do not change into a low gear at high engine speed.

#### Info

 If you hear unusual noises while riding, stop immediately, switch off the engine, and contact an authorized workshop. First gear is used for starting off and for steep inclines

Shift into a higher gear when conditions allow (incline, road situation, etc.) To do so, release the throttle while simultaneously pulling the clutch lever, shift into the next gear, release the clutch lever and open the throttle.

If the choke function has been activated, deactivate it after the engine has warmed up.

After reaching maximum speed by fully opening the throttle grip, turn the throttle back so it is 3/4 open. This will barely reduce the speed but fuel consumption will be considerably lower.

Always open the throttle only as much as the engine can handle - abrupt throttle opening increases fuel consumption.

To shift down, apply the brakes and close the throttle at the same time.

Pull the clutch lever and shift into a lower gear, release the clutch lever slowly, and either open the throttle or shift again.

Switch off the engine if running at idle or stationary for a long time.

Guideline

≥ 2 min

Avoid frequent and longer slipping of the clutch. As a result the gear oil, engine and cooling system heat up.

Ride at a low engine speed instead of at a high engine speed with a slipping clutch.

### 8.5 Applying the brakes



#### Warning

**Danger of accidents** Excessively forceful application of the brakes blocks the wheels.

Adjust application of the brakes to the respective riding situation and riding surface conditions.



#### Warning

**Danger of accidents** A spongy pressure point on the front or rear brake reduces braking efficiency.

Check the brake system and do not continue riding until the problem is eliminated. (Your authorized workshop will be glad to help.)



#### Warning

**Danger of accidents** Moisture and dirt impair the brake system.

Brake carefully several times to dry out and remove dirt from the brake linings and the brake discs.

On sandy, wet, or slippery surfaces, use the rear brake mostly if possible.

Always finish braking before you go into a bend. Change down to a lower gear appropriate to your road speed.

Use the braking effect of the engine on long downhill stretches. Change down one or two gears, but do not over-rev the engine.

You will have to apply the brakes far less frequently as a result and the brake system will not overheat.

## 8 RIDING INSTRUCTIONS

### 8 . 6 Stopping, parking



#### Warning

**Risk of misappropriation** People who act without authorization endanger themselves and others

- Do not leave the vehicle unattended if the engine is running.
- Protect the vehicle against access by unauthorized persons.



#### Warning

**Danger of burns** Some vehicle components become very hot when the vehicle is operated.

- Do not touch any parts such as the exhaust system, radiator, engine, shock absorber, or brake system before the vehicle parts have cooled down.
- Let the vehicle parts cool down before you perform any work on the vehicle.

#### Note

**Fire hazard** Hot vehicle components pose a fire hazard and explosion risk.

- Do not park the vehicle near to materials which are highly flammable or explosive.
- Allow the vehicle to cool down before covering it

#### Note

**Material damage** The vehicle may be damaged by incorrect procedure when parking.

Significant damage may be caused if the vehicle rolls away or falls over.  
The components for parking the vehicle are designed only for the weight of the vehicle.

- Park the vehicle on a firm and level surface.
- Ensure that nobody sits on the vehicle when the vehicle is parked on a stand.

Apply the brakes on the motorcycle .

Shift gear to neutral

Press and hold the kill switch while the engine is idling until the engine stops.

Turn handle 1 of the fuel tap to the OFF position .

Rest the vehicle on the plug-in stand.

### 8 . 7 Transport

#### Note

**Danger of damage** The parked vehicle can roll away or fall over.

- Park the vehicle on a firm and level surface.

#### Note

**Fire hazard** Hot vehicle components pose a fire hazard and explosion risk.

- Do not park the vehicle near to materials which are highly flammable or explosive.
- Allow the vehicle to cool down before covering it.

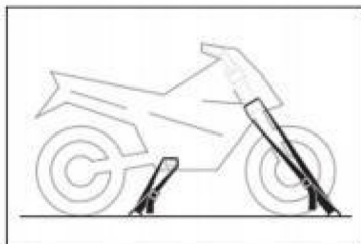

Switch off the engine.

Use tension belts or other suitable devices to secure the motorcycle against accidents or falling over.

### 8.8 Refueling



**Danger**

**Fire hazard** Fuel is highly flammable.

The fuel in the fuel tank expands when warm and can escape if overfilled

Do not refuel the vehicle in the vicinity of open flames or lit cigarettes.

Switch off the engine for refueling

Make sure that no fuel is spilled; particularly not on hot parts of the vehicle.

If any fuel is spilled, wipe it off immediately .

Observe the specifications for refueling



**Warning**

**Danger of poisoning** Fuel is poisonous and a health hazard

Avoid skin, eye and clothing contact with fuel.

Immediately consult a doctor if you swallow fuel

Do not inhale fuel vapors.

In case of skin contact, rinse the affected area with plenty of water

Rinse the eyes thoroughly with water, and consult a doctor in case of fuel contact with the eyes.

Change your clothing in case of fuel spills on them



**Warning**

**Environmental hazard** Improper handling of fuel is a danger to the environment.

Do not allow fuel to enter the groundwater, the soil, or the sewage system.

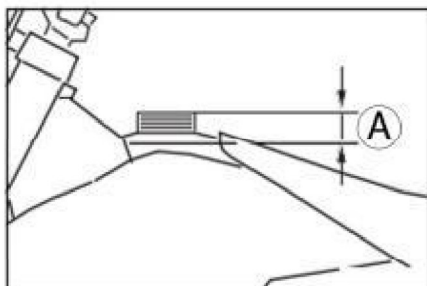

Switch off the engine.

Open the filler cap.

Fill the fuel tank with fuel up to measurement A.

Guideline

Measurement of <b>A</b>	35 mm(1.38 in)
	Super unleaded (98 octane) mixed with 2-stroke engine oil(140)
Engine oil, 2-stroke	

Close the filler cap.

## 9 SERVICE SCHEDULE

### 9.1 Additional information

Any further work that results from the required work or from the recommended work must be ordered separately and can be invoiced separately

Different service intervals may apply in your country . depending on the local operating conditions

### 9.2 Required work

	after every race			
	Every 40 operating hours	Every 20 operating hours	Every 10 operating hours	Once after 1 operating hour
Change the gear oil	●	●	●	
Check the front brake linings .	●	●	●	●
Check the rear brake linings .	●	●	●	●
Check the brake discs	●	●	●	
Check the brake lines for damage and leakage	●	●	●	●
Check the rear brake fluid level .	●	●	●	●
Check the free travel of the foot brake lever.	●	●	●	●
Check the frame	●	●	●	●
Check the swingarm .	●	●	●	●
Check the swingarm bearing for play.		●	●	
Check the joint for play.	●	●	●	
Check the shock absorber linkage.	●	●	●	●
Check the tire condition .	○	●	●	●
Check the tire air pressure .	○	●	●	●
Check the wheel bearing for play		●	●	●
Check the wheel hubs		●	●	●
Check the rim run-out	○	●	●	●
Check the spoke tension .	○	●	●	●
Chock the chain, rear sprocket,engine sprocket,and chain guide .		●	●	●
Check the chain tension .	○	●	●	●
Grease all moving parts (e.g. hand lever,chain,)and check for smooth operation.		●	●	●
Check/correct the fluid level of the hydraulic clutch		●	●	●
Check the front brake fluid level		●	●	●
Check the free travel of the hand brake lever		●	●	●
Check the play of the steering head bearing	○	●	●	●
Change the spark plug and spark plug connector.		●	●	●
Check all hoses(e.g. fuel,cooling,bleeder,drainage,etc )and sleeves for cracking,leaks,and incorrect routing	○	●	●	●
Check the antifreeze and coolant level	○	●	●	●
Check the cables for damage and for routing without kinks.		●	●	●
Check that the throttle cables are undamaged.routed without sharp bends, and set correctly	○	●	●	●
Clean the air filter and air filter box .		●	●	●
Change glass fiber yarn filling in the main silencer .		●	●	
Service the fork.			●	
Service the shock absorber.			●	
Check the screws and nuts lor tightness.	○	●	●	●
Check idle	○	●	●	●
Final check Check the vehicle for operating safety and take a test nde	○	●	●	●
Make the service entry in the <a href="http://www.zuumavmoto.com">www.zuumavmoto.com</a> and in the Service and Warranty Booklet.	○	●	●	●

0 One - time interval

## 9 SERVICE SCHEDULE

- Periodic interval

	after every race			
			Annually	
		Every 40 operating hours		
	Once after 20 operating hours/Every 20 operating hours			
	Once after 10 operating hours/Every 10 operating hours			
Change the front brake fluid			●	
Change the rear brake fluid			●	
Change the hydraulic clutch fluid .			●	
Grease the steering head bearing .			●	
Service the fork.	○			
Service the shock absorber.		○		
Check/adjust the carburetor components.			●	●
Perform minor engine service.(Check the inlet membrane.Check the clutch.Under difficult operating conditions: Change the piston and check the cylinder and Z dimension.)	●	●	●	●
Perform the intermediate engine service.(Change the piston and check the cylinder and Z dimension. Check the exhaust control for functioning and smooth operation.)		●	●	
Perform major engine service including removing and installing the engine.(Change the connecting rod. conrod bearing, and crank pin.Check the transmission and shift mechanism.Change all engine bearings .)			●	

- One- time interval
- Periodic interval

# 10 TUNING THE CHASSIS

## 10.1 Checking the basic chassis setting with the rider's weight

### **i** Info

When adjusting the basic chassis setting, first adjust the shock absorber and then the fork.

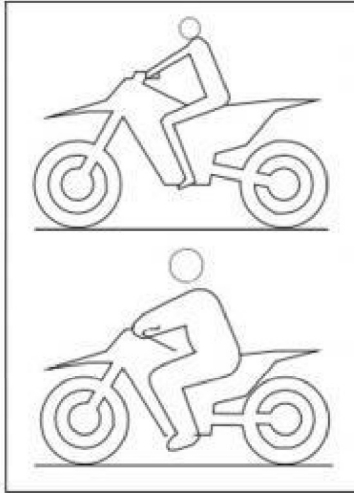

For optimal motorcycle riding characteristics and to avoid damage to forks, shock absorbers, swingarm and frame, the basic settings of the suspension components must match the rider's weight.

As delivered, off road motorcycles are adjusted for an average rider's weight (with full protective clothing).

Guideline

Standard rider weight	75--85 kg(165--187 lbs.)
-----------------------	--------------------------

If the rider's weight is above or below this range, the basic setting of the suspension components must be adjusted accordingly.

Small weight differences can be compensated by adjusting the spring preload, but in the case of large weight differences, the springs must be replaced.

## 10.2 Air suspension KKE 48



Air suspension **KKE 48** is used in the fork.

In this system, suspension is located in the left fork leg and damping in the right fork leg.

As fork springs are no longer required, a significant weight advantage is achieved when compared to conventional forks. The response on slightly uneven surfaces is significantly improved.

In normal driving mode, suspension is provided exclusively by an air cushion. A steel spring is located in the left fork leg as an end stop.

### **i** Info

If the fork is frequently overloaded, then the air pressure in the fork must be increased to avoid damage to the fork and frame.

The air pressure in the fork can be quickly adjusted for the rider's weight, surface conditions and the rider's preference using a fork pump. The fork does not have to be detached. The time-consuming mounting of harder or softer fork springs is not required.

If the air chamber loses air due to a damaged seal, the fork will still not sag. In this case, the air is retained in the fork. The suspension travel is maintained as far as possible. The damping becomes harder and the riding comfort reduces.

As with a conventional fork, the damping can be adjusted in rebound and compression stages.

The rebound adjuster is located at the lower end of the right fork leg.

The compression adjuster is located at the upper end of the right fork leg.

## 10.3 Compression damping of the shock absorber

The compression damping of the shock absorber is divided into two ranges: high-speed and low-speed.

High-speed and low-speed refer to the compression speed of the rear wheel suspension and not to the vehicle speed.

The high-speed setting, for example, has an effect on the landing after a jump: the rear wheel suspension compresses quickly.

The low-speed setting, for example, has an effect when riding over long ground swells: the rear wheel suspension compresses slowly.

These two ranges can be adjusted separately, although the transition between high-speed and low-speed is gradual. Thus, changes in the high-speed range affect the compression damping in the low-speed range and vice versa.

## 10 TUNING THE CHASSIS

### 10.4 Adjusting the low-speed compression damping of the shock absorber



#### Caution

**Risk of injury** Parts of the shock absorber will fly off if the shock absorber is disassembled incorrectly. The shock absorber is filled with highly compressed nitrogen.

Please follow the description provided. (Your authorized workshop will be glad to help.)



#### Info

The effect of the low-speed setting can be seen in slow to normal compression of the shock absorber.

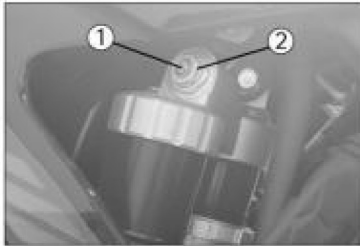

Turn adjusting screw **1** clockwise with a screwdriver up to the last perceptible click.



#### Info

Do not loosen fitting **2!**

Turn counterclockwise by the number of clicks corresponding to the shock absorber type  
Guideline

Compression damping, low-speed	
Comfort	17 clicks
Standard	15 clicks
Sport	13 clicks



#### Info

Turn clockwise to increase damping; turn counterclockwise to reduce damping.

### 10.5 Adjusting the high-speed compression damping of the shock absorber



#### Caution

**Risk of injury** Parts of the shock absorber will fly off if the shock absorber is disassembled incorrectly. The shock absorber is filled with highly compressed nitrogen.

Please follow the description provided. (Your authorized workshop will be glad to help.)



#### Info

The effect of the high-speed setting can be seen in fast compression of the shock absorber.

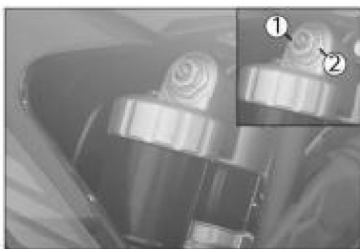

Turn adjusting screw **1** all the way clockwise with a socket wrench.



#### Info

Do not loosen fitting **2!**

Turn counterclockwise by the number of turns corresponding to the shock absorber type

## 1 0 TUNING THE CHASSIS

Guideline

Compression damping,high-speed	
Comfort	2 turns
Standard	1.5 turns
Sport	1 turn

**i Info**  
Turn clockwise to increase damping, turn counterclockwise to reduce damping.

### 10.6 Adjusting the rebound damping of the shock absorber

**⚠ Caution**  
**Risk of injury** Parts of the shock absorber will fly off if the shock absorber is disassembled incorrectly.  
The shock absorber is filed with highly compressed nitrogen.

Please follow the description provided.(Your authorized workshop will be glad to help.)

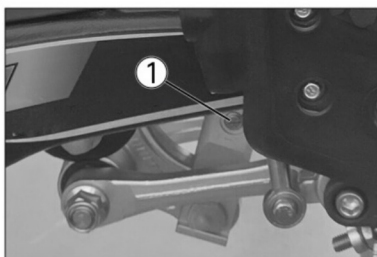

Turn adjusting screw 1 clockwise up to the last perceptible click.

Turn counterclockwise by the number of clicks corresponding to the shock absorber type

Guideline

Rebound damping	
Comfort	17 clicks
Standard	15 clicks
Sport	13 clicks

**i Info**  
Turn clockwise to increase damping; turn counterclockwise to reduce damping.

### 10.7 Measuring the rear wheel dimension unloaded

#### Preparatory work

Raise the motorcycle with a lift stand.

## 10 TUNING THE CHASSIS

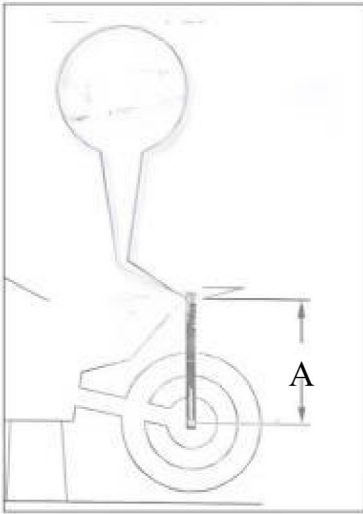

### Main work

Position the sag gauge in the rear axle and measure the distance to marking on the rear fender.

Sag gauge

Pin for sag gauge

Note down the value as dimension **A**

### Finishing work

Remove the motorcycle from the lift stand.

### 10.8 Checking the static sag of the shock absorber

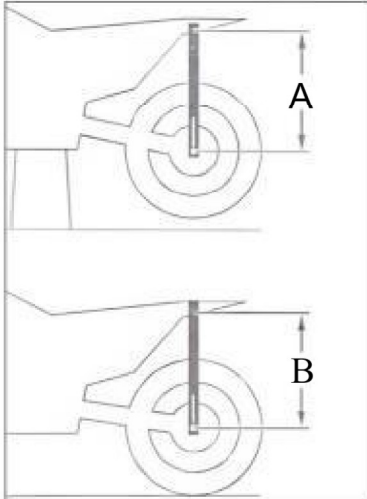

Measure dimension **A** of rear wheel unloaded

Hold the motorcycle upright with the aid of an assistant

Again measure the distance between the rear axle and marking on the rear fender using the sag gauge.

Note down the value as dimension **B**

#### **i** Info

The static sag is the difference between measurements A and

### **B** Check the static sag

Static sag	35 mm(1.38 in)
------------	----------------

If the static sag is less or more than the specified value:

Adjust the spring pretension of the shock absorber.4

## 1 0 TUNING THE CHASSIS

### 10.9 Checking the riding sag of the shock absorber

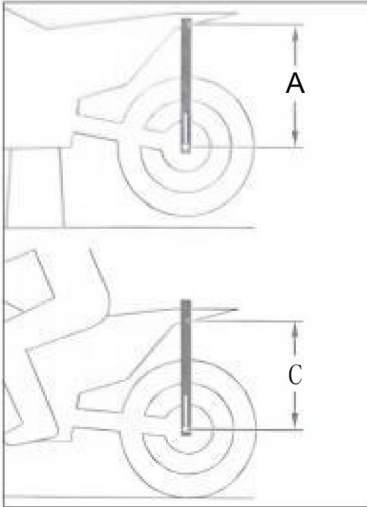

Measure dimension **A** of rear wheel unloaded  
With another person holding the motorcycle, the rider, wearing full protective clothing, sits on the seat in a normal sitting position (feet on footrests) and bounces up and down a few times.

The rear wheel suspension levels out.

Another person again measures the distance between the rear axle and marking on the rear fender using the saggauge.

Note down the value as dimension C

**i Info**  
The riding sag is the difference between measurements **A** and C

Check the riding sag

Guideline

Riding sag	105 mm (4.13 in)
------------	------------------

If the riding sag differs from the specified measurement.

Adjust the riding sag .

### 1 0 . 1 0 Adjusting the spring pretension of the shock absorber



#### Caution

**Risk of injury** Parts of the shock absorber will fly off if the shock absorber is disassembled incorrectly.

The shock absorber is filled with highly compressed nitrogen.

Please follow the description provided. (Your authorized workshop will be glad to help.)



#### Info

Before changing the spring pretension, make a note of the present setting, e.g., by measuring the length of the spring.

#### Preparatory work

Raise the motorcycle with a lift stand .

- Remove the shock absorber .

After removing the shock absorber, clean it thoroughly.

#### Main work

Loosen screw 1

Turn adjusting ring **2** until the spring is no longer under tension.

Hook wrench

Measure the overall spring length while the spring is not under tension.

Tighten the spring by turning adjusting ring **2** to measurement A

Guideline

Spring preload	6 mm (0.24 in)
----------------	----------------

#### i Info

Depending on the static sag and/or the riding sag, it may be necessary to increase or decrease the spring pretension.

Tighten screw 1 .

Guideline

Screw, shock absorber adjusting ring	M5	5 Nm (3.7 lbf ft)
--------------------------------------	----	-------------------

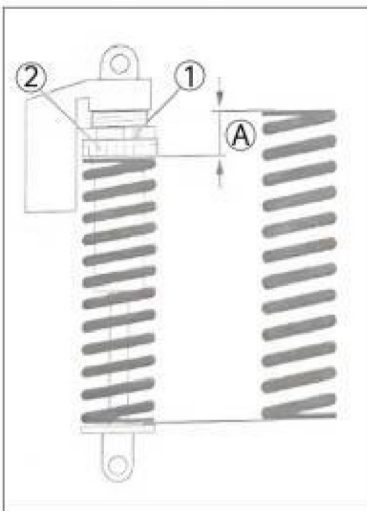

#### Finishing work

- Install the shock absorber .

- Remove the motorcycle from the lift stand.

## 10 TUNING THE CHASSIS

### 10.11 Adjusting the riding sag

#### Preparatory work

- Raise the motorcycle with a lift stand .
- Remove the shock absorber
- After removing the shock absorber, clean it thoroughly

#### Main work

- Choose and mount a suitable spring.
- Guideline

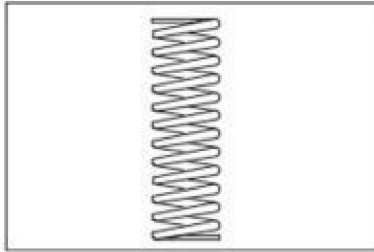

Spring rate	
Weight of rider: 65 . 75 kg (143 . 165 lb.)	36 N/mm (206 lb/in)
Weight of rider: 75 . 85 kg (165 . 187 lb.)	39 N/mm (223 lb/in)
Weight of rider: 85 . 95 kg (187 . 209 lb )	42 N/mm (240 lb/in)



#### Info

**The spring rate is shown on the outside of the spring .**

#### Finishing work

- Install the shock absorber .
- Remove the motorcycle from the lift stand.
- Check the static sag of the shock absorber.
- Check the riding sag of the shock absorber
- Adjust the rebound damping of the shock absorber.

### 10.12 Checking the basic setting of the fork



#### Info

For various reasons, no exact riding sag can be determined for the fork

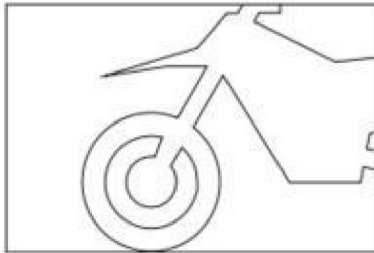

Smaller differences in the rider's weight can be compensated for by the fork air pressure.

However, if the fork frequently bottoms out ( hard end stop on compression), the fork air pressure must be increased, within the specified values, to avoid damage to the fork and frame.

If the fork feels unusually hard after extended periods of operation, the forklegs need to be bled.

# 10 TUNING THE CHASSIS

## 10.13 Adjusting the fork air pressure



### Warning

**Danger of accident** Modifications to the suspension setting may seriously affect the handling characteristic. Extreme modifications to the suspension setting may cause a serious deterioration in the handling characteristic and overload components.

Only make adjustments within the recommended range.

Ride slowly to start with after making adjustments to get the feel of the new handling characteristic.



### Info

Check or adjust the air pressure under the same conditions at the earliest 5 minutes after switching off the engine. The air suspension is located in the left forkleg. The pressure and rebound damping is located in the right forkleg.



### Preparatory work

Raise the motorcycle with a lift stand.

### Main work

Remove protection cap **1**

Push fork pump **2** together fully Fork pump



### Info

The fork pump is included as part of the motorcycle's separate enclosure.

Connect the fork pump to the left fork leg.

The fork pump indicator switches on automatically.

A little air escapes from the fork leg when connecting.



### Info

This is due to the volume of the hose and not due to a defect in the fork pump or the fork.

Read the accompanying **PowerParts** instructions.

Adjust the air pressure as specified

Guideline

Air pressure	8.5 bar (123 psi)
Changing of the air pressure in steps	0.2 bar (3 psi)
Minimum air pressure	7 bar (102 psi)



### Info

Never set the air pressure to a value outside the stated range.

Disconnect the fork pump from the left fork leg

When disconnecting, excess pressure will escape from the hose- the forkleg itself does not lose any air.

The fork pump indicator switches off automatically after 80 seconds.

- **Mount the** protection cap

### Finishing work

Remove the motorcycle from the lift stand.

## 10 TUNING THE CHASSIS

### 10.14 Adjusting the compression damping of the fork

**i Info**  
The hydraulic compression damping determines the fork suspension behavior.

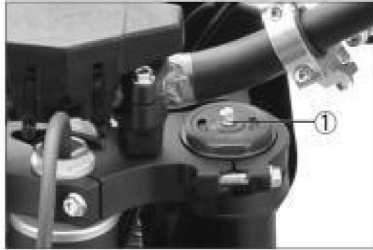

Turn adjusting screw 1 clockwise all the way

**i Info**  
Adjusting screw 1 is located at the upper end of the right fork leg  
Turn counterclockwise by the number of clicks corresponding to the fork type.  
Guideline

Compression damping	
Comfort	17 clicks
Standard	12 clicks
Sport	7 clicks

**i Info**  
Turn clockwise to increase damping; turn counterclockwise to reduce damping.

### 10.15 Adjusting the rebound damping of the fork

**Info**  
The hydraulic rebound damping determines the fork suspension behavior.

Remove protection cap 1  
Turn adjusting screw 2 clockwise all the way.

**i Info**  
Adjusting screw 2 is located at the lower end of the right fork leg  
Turn counterclockwise by the number of clicks corresponding to the fork type.  
Guideline

Rebound damping	
Comfort	17 clicks
Standard	12 clicks
Sport	7 clicks

**i Info**  
Turn clockwise to increase damping; turn counterclockwise to reduce damping

Mount protection cap 1

# 1 0 TUNING THE CHASSIS

## 10.16 Handlebar position

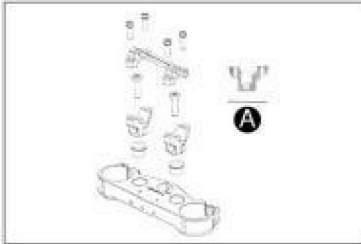

The holes on the handlebar supports are placed at a distance of A from the center .

Hole distance A	3.5 mm (0. 138 in)
-----------------	--------------------

The handlebar can be mounted in 2 different positions. In this way, the handlebar can be mounted in the most comfortable position for the rider.

## 10.17 Adjusting the handlebar position



### Warning

**Danger of accidents** A repaired handlebar poses a safety risk

If the handlebar is bent or straightened, the material becomes fatigued. The handlebar may break as a result

Change the handlebar if the handlebar is damaged or bent.

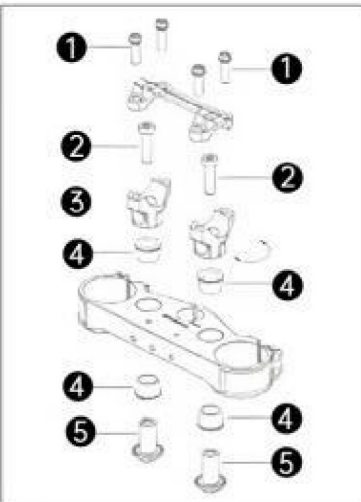

### Preparatory work

Remove the handlebar cushion.

### Main work

Remove screws 1. Remove the handlebar clamp. Remove the handlebar and lay it to one side.



### Info

Cover the components to protect them against damage.

Do not kink the cables and lines.

- Remove screws 2. Take off handlebar supports 3.

Position rubber bushings 4 and push through nuts 5 from below.

Place the handlebar supports in the required position.



### Info

The handlebar supports are longer and higher on one side.

Position the left and right handlebar supports evenly.

Mount and tighten screws 2

Guideline

Screw, handlebar support	M10	40 Nm (29.5 lbf ft)	
--------------------------	-----	------------------------	--

Position the handlebar



### Info

Make sure the cables and wiring are positioned correctly

Position the handlebar clamp

Mount screws 1 but do not tighten yet.

First bolt the handlebar clamp with screws 1 onto the longer, higher side of the handlebar supports so that both parts touch.

Guideline

Screw, handlebar clamp	M8	20 Nm (14.8 lbf ft)
------------------------	----	------------------------

Tighten screws 1 evenly

Guideline

Screw, handlebar clamp	M8	20 Nm (14.8 lbf ft)
------------------------	----	------------------------

## 10 TUNING THE CHASSIS

### **Finishing work**

Mount the handlebar cushion

## 1 1 SERVICE WORK ON THE CHASSIS

### 1 1.1 Raising the motorcycle with a lift stand

#### Note

**Material damage** The vehicle may be damaged by incorrect procedure when parking. Significant damage may be caused if the vehicle rolls away or falls over. The components for parking the vehicle are designed only for the weight of the vehicle.

Park the vehicle on a firm and level surface.

Ensure that nobody sits on the vehicle when the vehicle is parked on a stand.

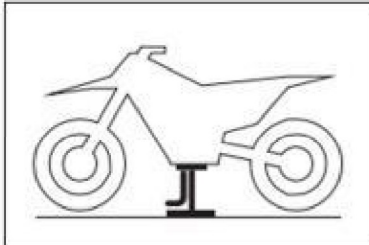

Raise the motorcycle at the frame underneath the engine.

Lift stand

Neither wheel is in contact with the ground .

Secure the motorcycle against falling over

### 11.2 Removing the motorcycle from the lift stand

#### Note

**Material damage** The vehicle may be damaged by incorrect procedure when parking. Significant damage may be caused if the vehicle rolls away or falls over. The components for parking the vehicle are designed only for the weight of the vehicle.

Park the vehicle on a firm and level surface.

Ensure that nobody sits on the vehicle when the vehicle is parked on a stand.

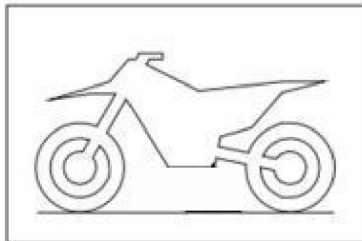

Remove the motorcycle from the lift stand

- Remove the lift stand.

To park the motorcycle, insert plug-in stand **1** into the left side of the wheel spindle .



#### Info

Remove the plug-in stand before riding.

### 11.3 Bleeding the fork legs

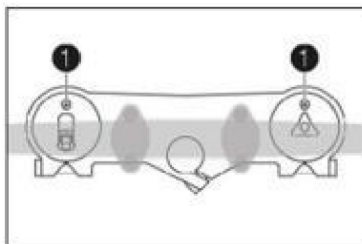

#### Preparatory work

Raise the motorcycle with a lift stand .

#### Main work

Release bleeder screws 1.

Any excess pressure escapes from the interior of the fork

Tighten the bleeder screws.

#### Finishing work

Remove the motorcycle from the lift stand.

## 11 SERVICE WORK ON THE CHASSIS

### 11.4 Cleaning the dust boots of the forklegs



#### Preparatory work

- Raise the motorcycle with a lift stand .
- Remove the fork protector.

#### Main work

Push dust boots 1 of both fork logs downward.



The dust boots remove dust and coarse dirt particles from the inside fork tubes. Over time, dirt can accumulate behind the dust boots. If this dirt is not removed, the oil seals behind can start to leak.



**Warning**  
**Danger of accidents** Oil or grease on the brake discs reduces the braking effect.

Always keep the brake discs free of oil and grease.  
Clean the brake discs with brake cleaner when necessary.

Clean and oil the dust boots and inner fork tubes of both fork legs.

Universal oil spray

Press the dust boots back into their normal position.  
Remove excess oil.

#### Finishing work

- Install the fork protector.
- Remove the motorcycle from the lift stand.

### 11.5 Removing the fork legs

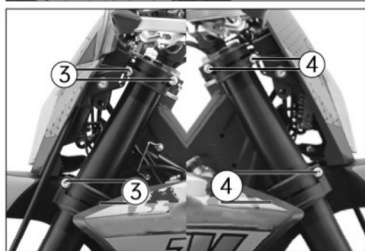

#### Preparatory work

- Raise the motorcycle with a lift stand .
- Remove the front wheel.

#### Main work

Remove screws and take off the clamp.

Remove screws 2 and take off the brake caliper.  
Allow the brake caliper and brake line to hang tension-free to the side.



**Info**  
Do not activate the hand brake lever while the front wheel is removed.

Unscrew screws 3. Take out the left fork leg.

- Unscrew screws 4. Take out the right fork leg.

## 11 SERVICE WORK ON THE CHASSIS

### 11.6 Installing the fork legs

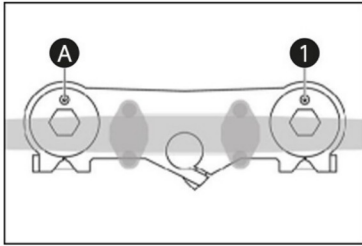

#### Main work

Position the fork legs

Bleeder screw **1** of the right fork leg is positioned to the front.

Valve **A** of the left fork leg faces the front

**i Info**  
Grooves are milled into the side of the upper end of the fork legs. The second milled groove (from the top) must be flush with the top edge of the upper triple clamp.

The air suspension is located in the left fork leg. The pressure and rebound damping is located in the right fork leg.

Tighten screws **2**

Guideline

Screw, top triple clamp	M8	17 Nm (12.5 lbf ft)
-------------------------	----	------------------------

Tighten screws **3**

Guideline

Screw, bottom triple clamp	M8	12 Nm (8.9 lbf ft)
----------------------------	----	--------------------

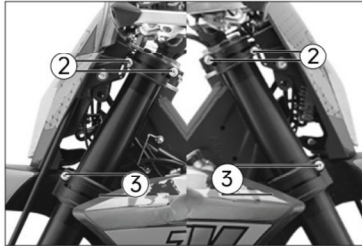

Position the brake caliper. Mount and tighten screws **4**.

Guideline

Screw, front brake caliper	M8	25 Nm (18.4 lbf ft)
----------------------------	----	------------------------

Position the brake line and clamp. Mount and tighten screws **5**



#### Finishing work

Install the front wheel.

### 11.7 Removing the fork protector

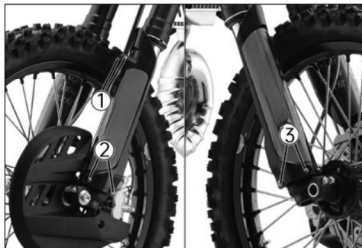

Remove screws **1**. Remove the clamp.

- Remove screws **2**. Take off the left fork protector.

Remove screws **3**. Take off the right fork protector.

### 11.8 Installing the fork protector



Position the fork protection on the left fork leg. Mount and tighten screws **1**

Guideline

Remaining screws, chassis	M6	10 Nm (7.4 lbf ft)
---------------------------	----	--------------------

Position the brake line and clamp. Mount and tighten screws **2**.

Position the fork protector on the right fork leg. Mount and tighten screws **3**.

Guideline

Remaining screws, chassis	M6	10 Nm (7.4 lbf ft)
---------------------------	----	--------------------

## 11 SERVICE WORK ON THE CHASSIS

### 11.9 Removing the lower triple clamp

#### Preparatory work

Raise the motorcycle with a lift stand .

Remove the front wheel 4

Remove the fork legs .

Remove the start number plate.

- Remove the front fender .

- Remove the handlebar cushion.

#### Main work

Remove screw 1 .

Remove screw 2 .

Pull off the upper triple clamp with the handlebar and hang to the side.

#### Info

-  Protect the components against damage by covering them.
- Do not kink the cables and lines.

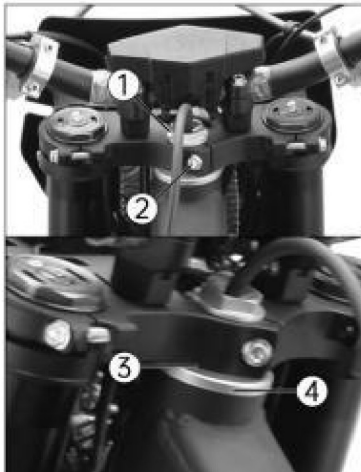

Remove O-ring 3. Remove protective ring 4

Take off the lower triple clamp with the steering stem.

Remove the upper steering head bearing.

### 11.10 Installing the lower triple clamp

#### Main work

Clean the bearing and sealing elements, check for damage, and grease.

High viscosity grease

Insert the lower triple clamp with the steering stem. Mount the upper steering head bearing.

Check whether upper steering head seal 1 is correctly positioned.

Slide on protective ring 2 and O-ring 3.

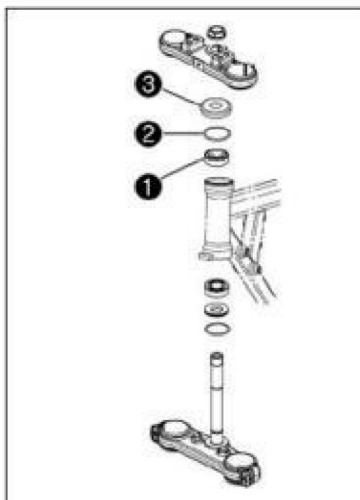

Position the upper triple clamp with the handlebar .

Mount screw 4 but do not tighten yet .



## 11 SERVICE WORK ON THE CHASSIS

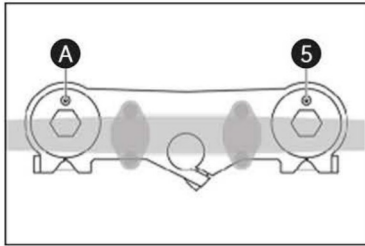

Position the fork legs

Bleeder screw 5 of the right fork leg is positioned to the front Valve A of the left fork leg faces the front.

### **i** Info

The air suspension **AER** valve is located in the left fork leg. Grooves are milled into the side of the upper end of the fork legs. The second milled groove (from the top) must be flush with the top edge of the upper triple clamp.



Tighten screws 6.

Guideline

Screw, bottom triple clamp	M8	12 Nm(8.9 lbf ft)
----------------------------	----	-------------------



Tighten screw 4.

Guideline

Screw, top steering head	M20x1.5	12 Nm(89 lbf ft)
--------------------------	---------	------------------



Mount and tighten screw 7.

Guideline

Screw, top steering stem	M8	20 Nm (14.8 lbf ft)
--------------------------	----	------------------------



-Tighten screws 8.

Guideline

Screw, top triple clamp	M8	17 Nm (12.5 lbf ft)
-------------------------	----	------------------------



Position the brake caliper. Mount and tighten screws 9.

Guideline

Screw, front brake caliper	M8	25 Nm (18.4 lbf ft)
----------------------------	----	------------------------

Position the brake line and clamp. Mount and tighten screws.

## 11 SERVICE WORK ON THE CHASSIS

### Finishing work

- Check that the wiring harness, throttle cables and brake and clutch lines can move freely and are routed correctly
- Install the front fender
- Install the front wheel .4
- Check the play of the steering head bearing
- Remove the motorcycle from the lift stand.
- Install the start number plate.
- Mount the handlebar cushion

### 11.1.1 Checking the play of the steering head bearing



#### Warning

**Danger of accidents** Incorrect steering head bearing play impairs the handling characteristic and damages component Correct incorrect steering head bearing play immediately. (Your authorized workshop will be glad to help)



#### Info

If the vehicle is operated for a lengthy period with play in the steering head bearing, the bearings and the bearing seats in the frame can become damaged over time.

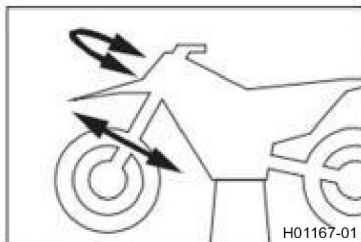

### Preparatory work

Raise the motorcycle with a lift stand.

### Main work

Move the handlebar to the straight-ahead position. Move the fork legs to and fro in the direction of travel

Play should not be detectable on the steering head bearing
--

If there is detectable play

Adjust the steering head bearing play.

Move the handlebar to and fro over the entire steering range

It must be possible to move the handlebar easily over the entire steering range. There should be no detectable detent positions.
--

If detent positions are detected:

Adjust the steering head bearing play.

Check the steering head bearing and change if necessary.

### Finishing work

- Remove the motorcycle from the lift stand.

### 11.1.2 Adjusting the steering head bearing play

#### Preparatory work

Raise the motorcycle with a lift stand.

- Remove the handlebar cushion.

#### Main work

Loosen screws 1

Remove screw 2 .

Loosen and retighten screw 3.

Guideline

Screw, top steering head	M20x1.5	12 Nm(8 .9 lbf ft)
--------------------------	---------	--------------------

Using a plastic hammer, tap lightly on the upper triple clamp to avoid stresses.

Tighten screws 1

Guideline

Screw, top triple clamp	M8	17 Nm (12 .5 lbf ft)
-------------------------	----	-------------------------

Mount and tighten screw 2

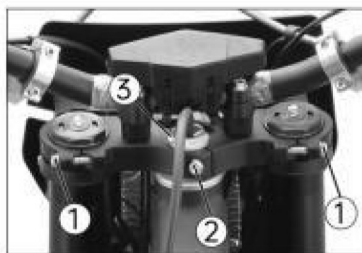

## 11 SERVICE WORK ON THE CHASSIS

### Guideline

Screw top steering stem	M8	20 Nm (14.8 lbf ft)	
-------------------------	----	------------------------	--

### Finishing work

Check the play of the steering head bearing.  
Remove the motorcycle from the lift stand .  
Mount the handlebar cushion

### 11.13 Greasing the steering head bearing

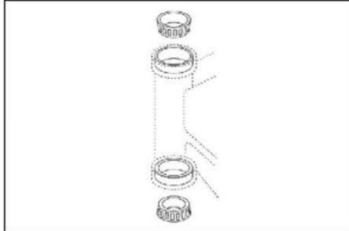

Remove the lower triple clamp .4  
Install the lower triple clamp .4

### 11.14 Removing the start number plate



Remove screw 1 .  
Disconnect the brake line at the start number plate. Take off the start number plate.

### 11.15 Installing the start number plate



Connect the brake line at the start number plate.  
Position the start number plate.  
The holding lugs engage in the fender.  
Mount and tighten screw 1 .

### 11.16 Removing the front fender

#### Preparatory work

Remove the start number plate .

#### Main work

- Remove screws 1 Remove the front fender .



## 11 SERVICE WORK ON THE CHASSIS

### 11.17 Installing the front fender



#### Main work

Position the front fender. Mount and tighten screws 1

Guideline

Remaining screws,chassis	M6	10 Nm(741bf)
--------------------------	----	--------------

#### Finishing work

- Install the start number plate .

### 11.18 Removing the shock absorber

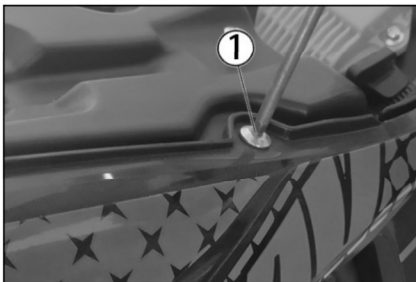

#### Preparatory wor

Raise the motorcycle with a lift stand.

#### Main work

Remove screws 1 with the washers and remove screws 2

-Remove the cable ties and remove the frame protectors on the left and night

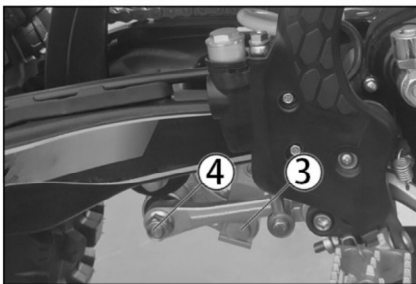

Removescrew 3.

Removefitting4 .



#### Info

Raise the wheel slightly to be able to remove the screws more easily.

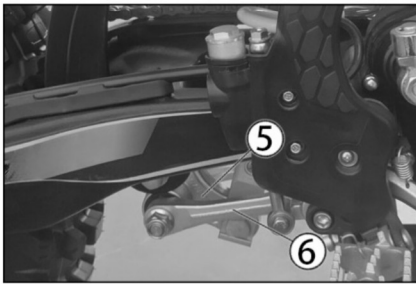

- Press angle lever 5 toward the rear.

Press linkage lever 6 downward.

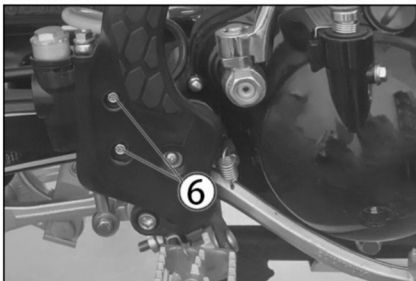

Remove screws 7 and pull foot brake cylinder off the push rod.

## 11 SERVICE WORK ON THE CHASSIS

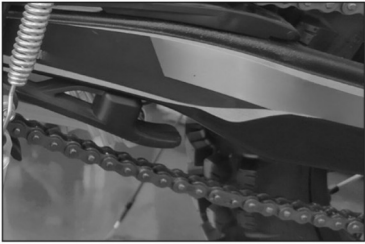

Remove the connecting link of the chain  
Take off the chain.

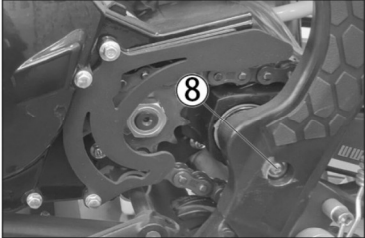

- Remove nut **8** and pull out the swing arm pivot .  
Push the swing arm back and secure it against falling over.



-Hold the shock absorber and remove screw 9.



Remove the shock absorber carefully at the bottom.

### 11.19 Installing the shock absorber

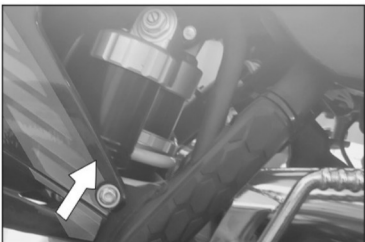

#### Main work

Carefully position the shock absorber into the vehicle from the bottom

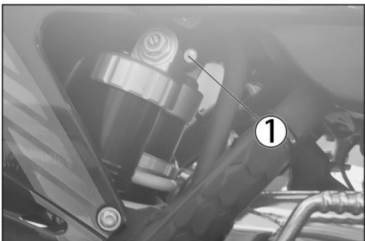

Mount and tighten screw 1.

Guideline

Screw, top shock absorber	M10	60 Nm (44.3 lbf ft)	
---------------------------	-----	------------------------	--

## 11 SERVICE WORK ON THE CHASSIS

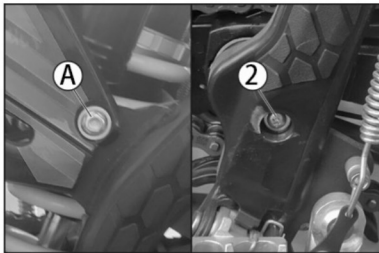

Position the swing arm and mount the swing arm pivot.

### **i** Info

Pay attention to flat area **A**

Mount and tighten nut 2

Guideline

Nut, swing arm pivot	M16x1.5	100 Nm (73 . 8lbf ft)
----------------------	---------	--------------------------



Mount the chain

Connect the chain with the connecting link

Guideline

The closed side of the chain joint lock must face in the direction of travel.

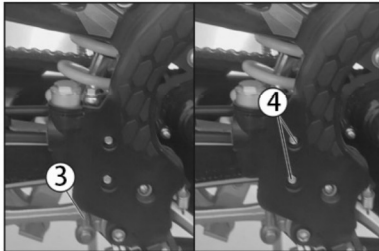

Position the foot brake cylinder.

Push rod **3** engages in the foot brake cylinder.

The dust boot is correctly positioned.

Mount and tighten screws 4.

Guideline

Remaining screws, chassis	M6	10 Nm (7.4 lbf ft)
---------------------------	----	--------------------

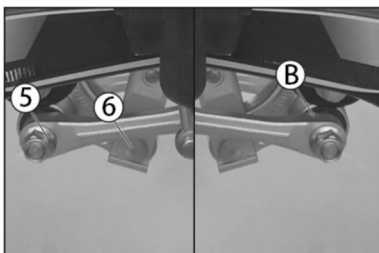

Position the angle lever and linkage lever

Mount and tighten fitting **5**

Guideline

Nut, linkage lever to angle lever	M14x1.5	80 Nm(59 lbf ft)
-----------------------------------	---------	------------------

### **i** Info

Pay attention to flat area

Mount and tighten screw **6**.

Guideline

Screw, bottom shock absorber	M10	60 Nm (44.3 lbf ft)
------------------------------	-----	------------------------

### **i** Info

Raise the wheel slightly to be able to mount the screw more easily

Position the frame protectors on the left and right.

Mount and tighten screws 7 with the washers and mount and tighten screws 8.

Guideline

Screw, frame protector	M5	3 Nm(2 .2 lbf ft)
------------------------	----	-------------------

Mount the cable tie(s).

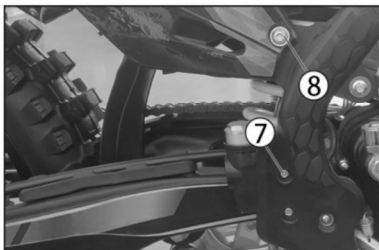

### Finishing work

Remove the motorcycle from the lift stand .

## 11 SERVICE WORK ON THE CHASSIS

### 11.20 Removing the seat



Remove screws 1

Raise the rear of the seat, pull the seat back, and lift it off.

### 11.21 Mounting the seat

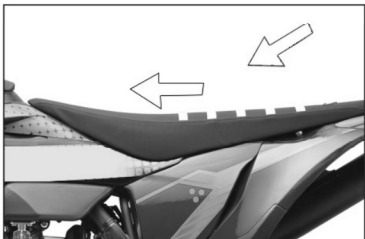

Mount the front of the seat on the collar bushing of the fuel tank, lower the seat at the rear, and push the seat forward.

Make sure that the seat is correctly locked in.



Mount and tighten screws 1

Guideline

Remaining screws, chassis	M6	10 Nm(7 .4 lbf ft)
---------------------------	----	--------------------

### 11.22 Removing the air filter box cover



#### Condition

The air filter box cover is secured.

- Remove screw 1.

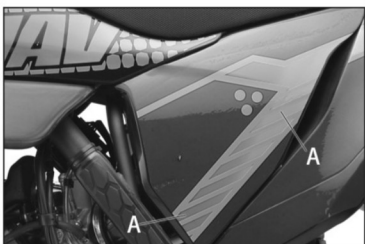

Pull off the air filter box cover in area A sideways and remove it toward the front .

## 11 SERVICE WORK ON THE CHASSIS

### 11.23 Installing the air filter box cover

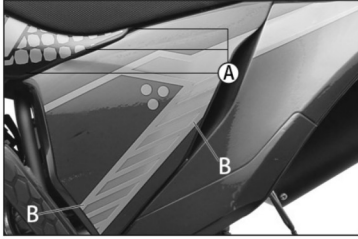

Insert the air filter box cover in area **A** and clip it into area **B**

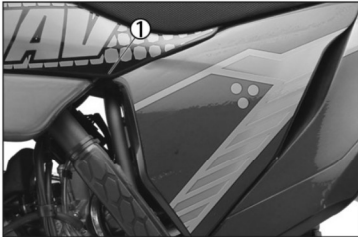

#### Condition

The air filter box cover is secured.

-Mount and tighten screw 1.

#### Guideline

Screw, air filter box cover		3 Nm (2.2 lbf ft)	screw
-----------------------------	--	----------------------	-------

### 11.24 Removing the air filter

#### Note

**Engine damage** Unfiltered intake air has a negative effect on the service life of the engine.

Dust and dirt will enter the engine without an air filter.

Never start to use the vehicle without an air filter.



#### Warning

**Environmental hazard** Hazardous substances cause environmental damage .

Dispose of oils, grease, filters, fuel, cleaning agents, brake fluid, etc. , correctly and in compliance with the applicable regulations.

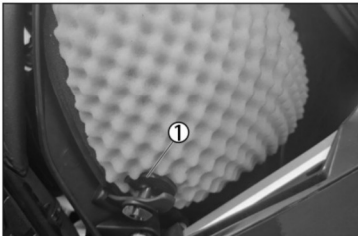

#### Preparatory work

Remove the air filter box cover .

#### Main work

Detach retaining tab 1. Remove air filter with air filter support.  
Take off air filter from air filter support.

### 11.25 Cleaning the air filter and air filter box



#### Warning

**Environmental hazard** Hazardous substances cause environmental damage

Dispose of oils, grease, filters, fuel, cleaning agents, brake fluid, etc., correctly and in compliance with the applicable regulations.



#### Info

Do not clean the air filter with fuel or petroleum since these substances attack the foam.

#### Preparatory work

Remove the air filter box cover

Remove the air filter .4

## 11 SERVICE WORK ON THE CHASSIS

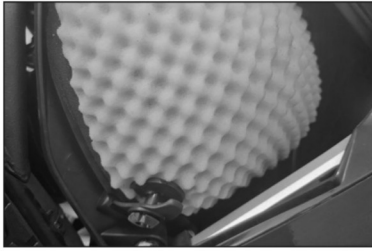

### Main work

Wash the air filter thoroughly in special cleaning liquid and allow it to dry properly.

Air filter cleaner



### Info

Only squeeze the air filter to dry it; never wring it out.

Oil the dry air filter with a high quality filter oil .

Oil for foam air filter

-Clean the air filter box.

Clean the intake flange and check it for damage and tightness

### Finishing work

Install the air filter

Install the air filter box cover.

### 11.26 Installing the air filter

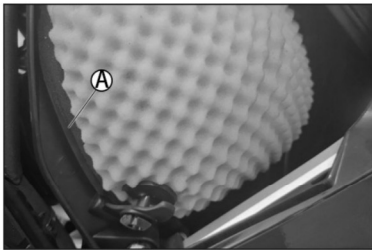

### Main work

Mount the clean air filter on the air filter support.

Grease the air filter in area **A**

Long- life grease

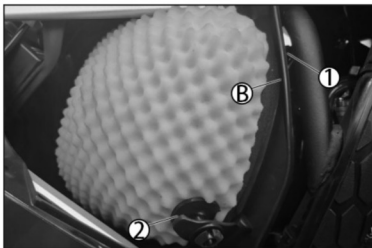

Insert the air filter and position the top retaining pin 1 in bushing B.

The air filter is correctly positioned .

Secure the bottom retaining pin with holding tab 2



### Info

If the air filter is not mounted correctly, dust and dirt may enter the engine and result in damage.

### Finishing work

Install the air filter box cover

### 11.27 Securing the air filter box cover



### Preparatory work

Remove the air filter box cover.

### Main work

Drill a hole at marking **A**

Guideline

Diameter

6 mm (0.24 in)

### Finishing work

Install the air filter box cover

## 11 SERVICE WORK ON THE CHASSIS

### 11.28 Sealing the air filter box

#### Preparatory work

Remove the air filter box cover.

#### Main work

Seal the air filter box in marked area **A**

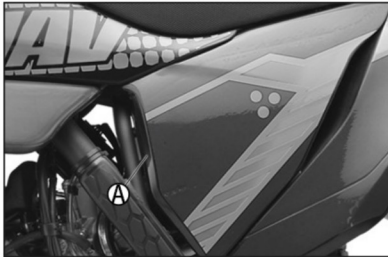

#### Finishing work

- Install the air filter box cover .

### 11.29 Removing the main silencer



#### Warning

**Danger of burns** The exhaust system gets very hot when the vehicle is driven.

Allow the exhaust system to cool down before performing any work on the vehicle.

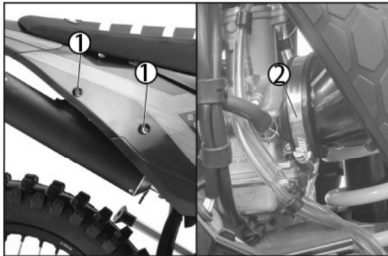

Remove screws **1** with the washers.

Pull off the main silencer from the manifold at rubber sleeve **2**

### 11.30 Installing the main silencer

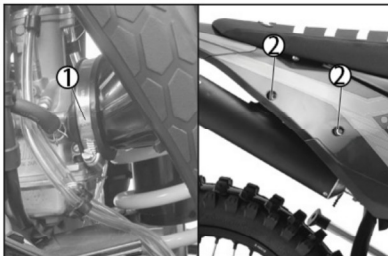

Position the main silencer with rubber sleeve **1**

Mount and tighten screws **2** with the washers.

Guideline

Remaining screws, chassis	M6	10 Nm(7 .4 lbf ft)
---------------------------	----	--------------------

### 11.31 Changing the glass fiber yarn filling in the main silencer



#### Warning

**Danger of burns** The exhaust system gets very hot when the vehicle is driven.

Allow the exhaust system to cool down before performing any work on the vehicle.



#### Info

Overtime, the fibers of the glass fiber yarn escape and the damper "burns" out. Not only is the noise level higher, the performance characteristic changes.

#### Preparatory work

Remove the main silencer

## 11 SERVICE WORK ON THE CHASSIS

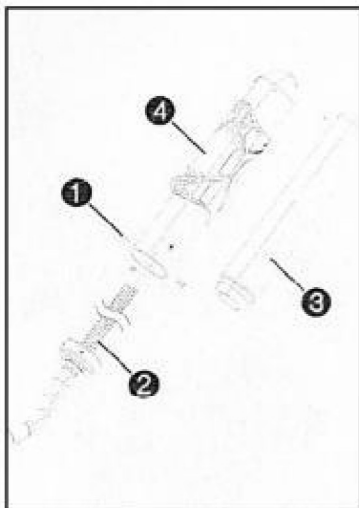

### Main work

- Remove screws 1. Pull out inner tube 2.
- Remove the glass fiber yarn filling 3 from the inner tube.
- Clean the parts that need to be reinstalled and check for damage.
- Fit the new glass fiber yarn filling 3 into the inner tube.
- Slide outer tube 4 over the inner tube with the new glass fiber yarn filling.
- Mount and tighten all screws 1.

### Guideline

Screws on the main silencer	M 5	7 Nm (5.2  bff)
-----------------------------	-----	-----------------

### Finishing work

- Install the main silencer.

### 11.32 Removing the fuel tank



#### Danger-

**Fire hazard** Fuel is highly flammable.

The fuel in the fuel tank expands when warm and can escape if overfilled.

- Do not refuel the vehicle in the vicinity of open flames or lit cigarettes.
- Switch off the engine for refueling.
- Make sure that no fuel is spilled; particularly not on hot parts of the vehicle.
- If any fuel is spilled, wipe it off immediately.
- Observe the specifications for refueling.



#### Warning

**Danger of poisoning** Fuel is poisonous and a health hazard.

- Avoid skin, eye and clothing contact with fuel.
- Immediately consult a doctor if you swallow fuel.
- Do not inhale fuel vapors.
- In case of skin contact, rinse the affected area with plenty of water.
- Rinse the eyes thoroughly with water, and consult a doctor in case of fuel contact with the eyes.
- Change your clothing in case of fuel spills on them.
- Keep fuels correctly in a suitable canister, and out of the reach of children.

### Preparatory work

- Remove the seat.
- Turn handle 1 of the fuel tap to the OFF position.

### Main work

- Pull off the fuel hose.



#### Info

Remaining fuel may flow out of the fuel hose.

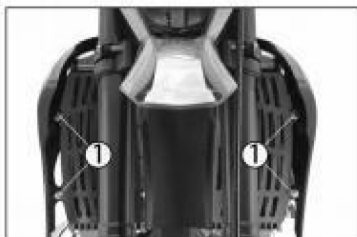

- Remove screws 1.

## 11 SERVICE WORK ON THE CHASSIS



Remove screw 2 with the rubber bushing  
Pull the fuel tank breather hose off the tank lid

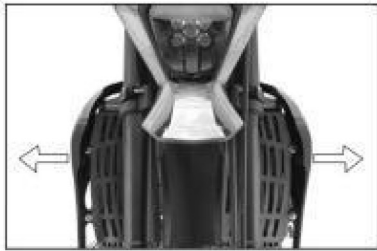

Pull both spoilers off the sides of the radiator bracket and lift off the fuel tank.

### 11.33 Installing the fuel tank



#### **Danger**

**Fire hazard** Fuel is highly flammable.

The fuel in the fuel tank expands when warm and can escape if overfilled.

Do not refuel the vehicle in the vicinity of open flames or lit cigarettes.

- Switch the engine for refueling .
- Make sure that no fuel is spilled; particularly not on hot parts of the vehicle .
- If any fuel is spilled, wipe it off immediately .

Observe the specifications for refueling



#### **Warning**

**Danger of poisoning** Fuel is poisonous and a health hazard

Avoid skin, eye and clothing contact with fuel.

Immediately consult a doctor if you swallow fuel.

Do not inhale fuel vapors.

In case of skin contact, rinse the affected area with plenty of water

Rinse the eyes thoroughly with water, and consult a doctor in case of fuel contact with the eyes.

Change your clothing in case of fuel spills on them.

#### **Main work**

Check the throttle cable routing

Position the fuel tank and fit the two spoilers to the sides of the radiator bracket

Make sure that no cables or throttle cables are trapped or damaged.

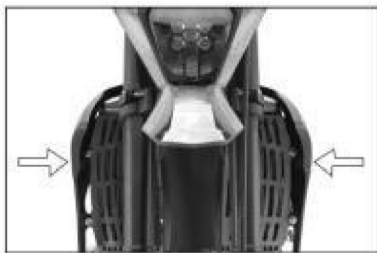

## 11 SERVICE WORK ON THE CHASSIS



Mount the fuel tank breather hose.  
Mount and tighten screw 1 with the rubber bushing

Guideline

Remaining screws, chassis	M6	10 Nm (7.4 lbf ft)
---------------------------	----	--------------------

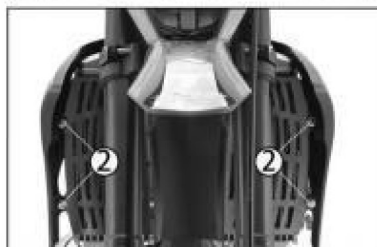

Mount and tighten screws 2.

Guideline

Remaining screws, chassis	M6	10 Nm (7.4 lbf ft)
---------------------------	----	--------------------

Connect the fuel hose.

### Finishing work

- Mount the seat .

### 11.34 Checking the chain for dirt

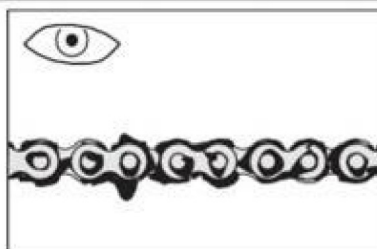

Check the chain for heavy soiling

If the chain is very dirty:  
Clean the chain.

### 11.35 Cleaning the chain



Warning

**Danger of accidents** Oil or grease on the tires reduces the road grip.

Remove the lubricant from the tires using a suitable cleaning agent.



Warning

**Danger of accidents** Oil or grease on the brake discs reduces the braking effect

Always keep the brake discs free of oil and grease.

Clean the brake discs with brake cleaner when necessary.



Warning

**Environmental hazard** Hazardous substances cause environmental damage.

Dispose of oils, grease, filters, fuel, cleaning agents, brake fluid, etc. correctly and in compliance with the applicable regulation



Info

The service life of the chain depends largely on its maintenance.

### Preparatory work

Raise the motorcycle with a lift stand.

## 11 SERVICE WORK ON THE CHASSIS

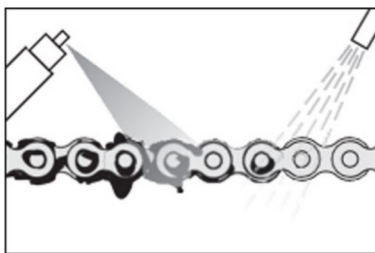

### Main work

Rinse off loose dirt with a soft jet of water  
Remove old grease residue with chain cleaner.

Chain cleaner

After drying, apply chain spray

Off-road chain spray

### Finishing work

Remove the motorcycle from the lift stand

### 11.36 Checking the chain tension



#### Warning-

**Danger of accidents** Incorrect chain tension damages components and results in accidents

If the chain is tensioned too much, the chain, engine sprocket, rear sprocket, transmission and rear wheel bearings wear more quickly. Some components may break if overloaded.

If the chain is too loose, the chain may fall off the engine sprocket or the rear sprocket. As a result, the rear wheel locks or the engine will be damaged.

- Check the chain tension regularly.

Set the chain tension in accordance with the specification.

### Preparatory work

Raise the motorcycle with a lift stand.

### Main work

Pull the chain at the end of the chain sliding piece upward to measure chain tension **A**.

Guideline

The lower chain section must be taut.

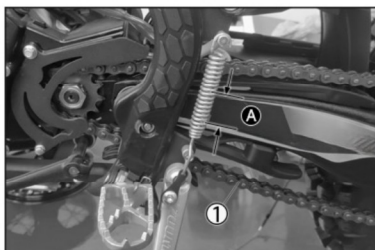

#### Info

Chain wear is not always even, so you should repeat this measurement at different chain positions.

Chain tension

55...58 mm (2.17... 2.28 in)

If the chain tension does not meet the specification:

Adjust the chain tension.

### Finishing work

Remove the motorcycle from the lift stand.

### 11.37 Adjusting the chain tension



#### Warning

**Danger of accidents** Incorrect chain tension damages components and results in accidents.

If the chain is tensioned too much, the chain, engine sprocket, rear sprocket, transmission and rear wheel bearings wear more quickly. Some components may break if overloaded.

If the chain is too loose, the chain may fall off the engine sprocket or the rear sprocket. As a result, the rear wheel locks or the engine will be damaged.

Check the chain tension regularly

Set the chain tension in accordance with the specification

### Preparatory work

Raise the motorcycle with a lift stand.

Check the chain tension.

# 11SERVICE WORK ON THE CHASSIS



### Main work

Loosen nut **1**

Loosen nuts **2**

Adjust the chain tension by turning adjusting screws **3** to the left and right .

Guideline

Chain tension	55...58 mm(2.17 ...2.28 in)	
Turn adjusting screws <b>3</b> on the left and right so that the markings on the left and right chain adjusters are in the same position relative to reference marks <b>A</b> .The rear wheel is now correctly aligned.		

Tighten nuts **2**.

Make sure that chain adjusters **4** are fitted correctly on adjusting screws **3**

Tighten nut **1**

Guideline

Nut, rear wheel spindle	M25x1.5	80 Nm (59 lbf ft)
-------------------------	---------	-------------------



### Info

The wide adjustment range of the chain adjusters(32 mm) on enable different secondary ratios with the same chain length

Chain adjusters **4** can be turned by 180°

### Finishing work

Remove the motorcycle from the lift stand.

## 1 1.3 8 Checking the chain, rear sprocket, engine sprocket, and chain guide

### Preparatory work

- Raise the motorcycle with a lift stand .

### Main work

Shift the transmission to idle.

Check the rear sprocket and engine sprocket for wear.

If the rear sprocket and engine sprocket are worn

Change the drive train kit **A**



### Info

The engine sprocket, rear sprocket, and chain should always be replaced together.

Pull at the top part of the chain with the specified weight **A** .

Guideline

Weight, chain wear measurement	10... 15 kg(22 ... 33 lb . )
--------------------------------	------------------------------

Measure distance of 18 chain rollers in the lower chain section.



### Info

Chain wear is not always even, so you should repeat this measurement at different chain positions

Maximum distance <b>B</b> at the longest chain section	272 mm(10.71 in)
--	------------------

If distance is greater than the specified measurement;

Change the drive train **kit**



### Info

When the chain is replaced, the rear sprocket and engine sprocket should also be changed.

New chains wear out faster on old, worn sprockets.

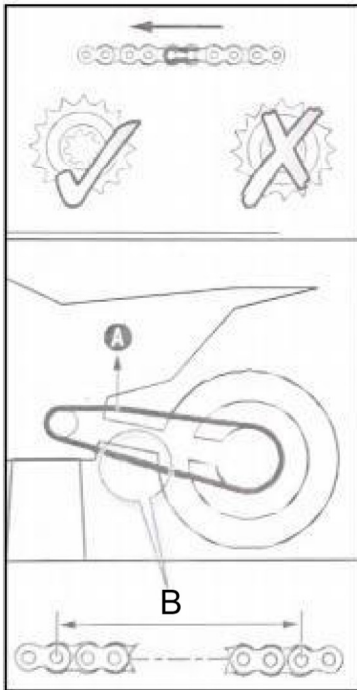

## 11 SERVICE WORK ON THE CHASSIS



Check the chain sliding guard for wear

If the lower edge of the chain pins is in line with or below the chain sliding guard:

Change the chain sliding guard

Check that the chain sliding guard is firmly seated

If the chain sliding guard is loose:

Tighten the screws on the chain sliding guard

Guideline

Screw, chain sliding guard	M6	6 Nm (4.4 lbf ft)	
----------------------------	----	----------------------	--

Check the chain sliding piece for wear

If the lower edge of the chain pins is in line with or below the chain sliding piece.

- Change the chain sliding piece.

Check that the chain sliding piece is firmly seated.

If the chain sliding piece is loose:

Tighten the screw on the chain sliding piece

Guideline

Screw, chain sliding piece	M8	15 Nm (11.1 lbf ft)	
----------------------------	----	------------------------	--

Check the chain guide with a slide gauge for dimension C

Minimum thickness C of the chain guide	6 mm (0.24 in)
--	----------------

If the measured value is less than the specification:

Change the chain guide.4

-Check that the chain guide is firmly seated.

If the chain guide is loose:

Tighten the screws on the chain guide.

Guideline

Remaining screws, chassis	M6	10 Nm (7.4 lbf ft)
Remaining nuts, chassis	M6	10 Nm (7.4 lbf ft)

### Finishing work

Remove the motorcycle from the lift stand.

## 1 1 SERVICE WORK ON THE CHASSIS

### 11.39 Checking the frame



Check the frame for cracks and deformation

If the frame exhibits cracks or deformation due to a mechanical impact

Change the frame 4



#### Info

Always replace a frame that has been damaged due to a mechanical impact. Repair of the frame is not authorized by

### 11.40 Checking the swingarm



Check the swingarm for damage, cracking, and deformation.

If the swingarm shows signs of damage, cracking, or deformation

Change the swingarm



#### Info

Always change a damaged swingarm. Repair of the swingarm is not authorized by .

### 11.41 Checking the throttle cable routing



#### Warning

**Danger of accidents** The throttle cable may slip out of the guide if routed incorrectly. The throttle slide will then no longer be closed and the speed can no longer be controlled.

Make sure that the throttle cable routing and the play in throttle cable complies with the specification.

#### Preparatory work

Remove the seat .

Turn handle 1 of the fuel tap to the OFF position .

Remove the fuel tank .

#### Main work

Check the throttle cable routing.

The throttle cable must be routed along the back of the handlebar, to the right of the frame, above the fuel tank bracket, and to the carburetor. The throttle cable

must be fixed on the fuel tank bracket with a rubber band.

If the throttle cable is not routed as specified:

-Correct the throttle cable routing.



#### Finishing work

Install the fuel tank

- Mount the seat.

## 11 SERVICE WORK ON THE CHASSIS

### 11.42 Checking the rubber grip

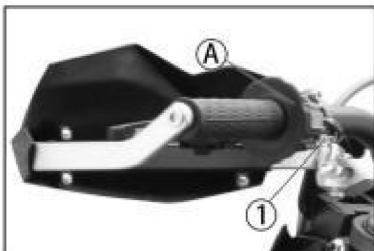
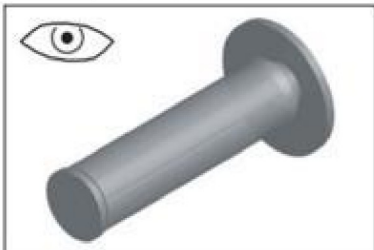

Check the rubber grips on the handlebar for damage, wear, and looseness.

#### **i** Info

The rubber grips are vulcanized onto a sleeve on the left and onto the handle tube of the throttle grip on the right. The left sleeve is clamped onto the handlebar.

The rubber grip can only be replaced with the sleeve or the throttle tube.

If a rubber grip is damaged or worn,

Change the rubber grip.

Check that screw 1 is firmly seated.

Guideline

Screw, fixed grip	M4	5 Nm (3.7 lbf ft)	
-------------------	----	----------------------	--

Diamond **A** must be located at the top.

### 11.43 Adjusting basic position of clutch lever

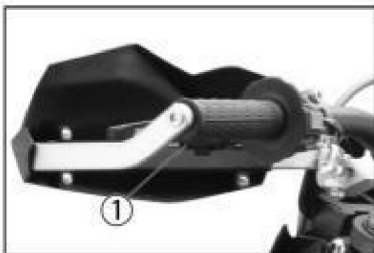

Adjust the basic setting of the clutch lever to your hand size by turning adjusting screw.

#### **i** Info

Turn the adjusting screw counterclockwise to decrease the distance between the clutch lever and the handlebar.

Turn the adjusting screw clockwise to increase the distance between the clutch lever and the handlebar.

The range of adjustment is limited.

Turn the adjusting screw by hand only, and do not apply any force.

Do not make any adjustments while riding.

### 11.44 Checking/ correcting the fluid level of the hydraulic clutch



**Warning**  
**Skin irritation** Brake fluid causes skin irritation.

- Keep brake fluid out of the reach of children.
- Wear suitable protective clothing and safety glasses.
- Do not allow brake fluid to come into contact with the skin, the eyes or clothing.

Consult a doctor immediately if brake fluid has been swallowed.

Rinse the affected area with plenty of water in the event of contact with the skin.

Rinse eyes thoroughly with water immediately and consult a doctor if brake fluid comes into contact with the eyes.

If brake fluid spills on to your clothing, change the clothing.



#### **Info**

The fluid level rises with increasing wear of the clutch facing discs.

Never use DOT 5 brake fluid. It is silicone-based and purple in color. Oil seals and clutch lines are not designed for DOT 5 brake fluid.

Avoid contact between brake fluid and painted parts. Brake fluid attacks paint.

Only use clean brake fluid from a sealed container.

## 11 SERVICE WORK ON THE CHASSIS

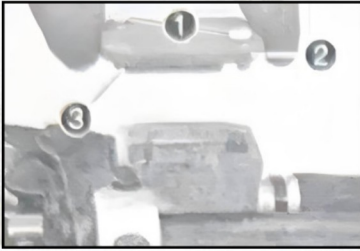

Move the clutch fluid reservoir mounted on the handlebar to a horizontal position. Remove screws 1.

Remove cover 2 with membrane 3.

Check the fluid level.

Fluid level below container rim	4 mm (0.16 in)
---------------------------------	----------------

If the fluid level does not meet specifications:

Correct the fluid level of the hydraulic clutch.

Brake fluid DOT4/DOT5 .
-------------------------

Position the cover with the membrane. Mount and tighten the screws.



### Info

Clean up overflowed or spilled brake fluid immediately with water.

### 11.45 Changing the hydraulic clutch fluid



#### Warning

**Skin irritation** Brake fluid causes skin irritation.

Keep brake fluid out of the reach of children.

Wear suitable protective clothing and safety glasses.

Do not allow brake fluid to come into contact with the skin, the eyes or clothing.

Consult a doctor immediately if brake fluid has been swallowed.

Rinse the affected area with plenty of water in the event of contact with the skin.

Rinse eyes thoroughly with water immediately and consult a doctor if brake fluid comes into contact with the eyes.

If brake fluid spills on to your clothing, change the clothing.



#### Warning

**Environmental hazard** Hazardous substances cause environmental damage.

Dispose of oils, grease, filters, fuel, cleaning agents, brake fluid, etc., correctly and in compliance with the applicable regulations.



### Info

Never use DOT 5 brake fluid. It is silicone-based and purple in color. Oil seals and clutch lines are not designed for DOT 5 brake fluid.

Avoid contact between brake fluid and painted parts. Brake fluid attacks paint.

Only use clean brake fluid from a sealed container.

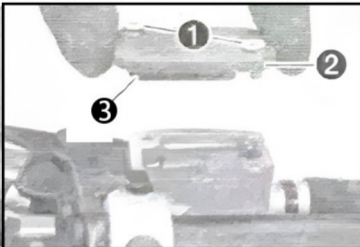

Move the clutch fluid reservoir mounted on the handlebar to a horizontal position.

Remove screws 1.

Remove cover 2 with membrane 3.

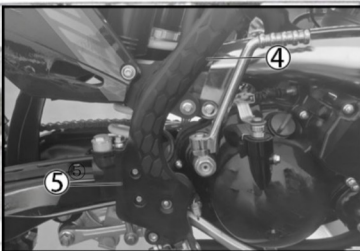

Fill bleeding syringe 4 with the appropriate hydraulic fluid.

Bleed syringe
Brake fluid DOT 4 /DOT 5.1

On the clutch slave cylinder, remove bleeder screw 5 and mount bleeding syringe 4.

## 11 SERVICE WORK ON THE CHASSIS



Now inject the liquid into the system until it emerges from the drill hole **6** of the master cylinder without bubbles.

Now and then, extract fluid from the master cylinder reservoir to prevent overflow.

Remove the bleeding syringe. Mount and tighten screws bleeder screw

Correct the fluid level of the hydraulic clutch.

Guideline

Fluid level below container rim	4 mm(0 . 16 in)
---------------------------------	-----------------

Position the cover with the membrane Mount and tighten the screws



### **Info**

Clean up overflowed or spilled brake fluid immediately with water.

## 12 BRAKESYSTEM

### 12.1 Checking the free travel of the hand brake lever



#### Warning

**Danger of accidents** The brake system fails in the event of overheating.

If there is no free travel on the hand brake lever, pressure builds up on the front brake circuit

Set the free travel on the hand brake lever in accordance with the specification



Push the hand brake lever forward and check free travel **A**

Free travel of hand brake lever	$\geq 3\text{mm}$ ( $\geq 0.12\text{in}$ )
---------------------------------	--

If the free travel does not meet specifications

Adjust the basic position of the hand brake lever.

### 12.2 Adjusting the basic position of the hand brake lever

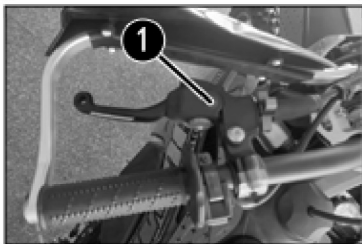

Check the free travel of the hand brake lever.

Adjust the basic position of the hand brake lever to your hand size by turning adjusting screw 1.

#### Info

Turn the adjusting screw clockwise to increase the distance between the hand brake lever and the handlebar.

Turn the adjusting screw counterclockwise to decrease the distance between the hand brake lever and the handlebar.

The range of adjustment is limited.

Only turn the adjusting screw by hand, and do not use force.

Do not make any adjustments while riding.

### 12.3 Checking the brake discs



#### Warning

**Danger of accidents** Worn-out brake discs reduce the braking effect.

Make sure that worn-out brake discs are replaced immediately. (Your authorized workshop will be glad to help.)

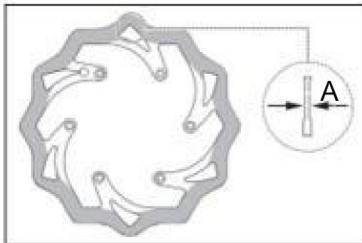

Check the thickness of the front and rear **brake** discs at multiple points on each brake disc to ensure it is at least thickness A

#### Info

Wear reduces the thickness of the brake disc around the area used by the brake linings.

Brake discs -wear limit

Front	2.5 mm (0.098 in)
Rear	3.5 mm (0.138 in)

If the brake disc thickness is less than the specified value

Change the front brake disc.

Change the rear brake disc.

Check the front and rear brake discs for damage, cracking, and deformation.

If the brake disc exhibits damage, cracking, or deformation:

Change the front brake disc

Change the rear brake disc

## 12 BRAKESYSTEM

### 12.4 Checking the front brake fluid level



#### Warning

**Danger of accidents** An insufficient brake fluid level will cause the brake system to fail

If the brake fluid level drops below the specified marking or the specified value, the brake system is leaking or the brake linings are worn down .

Check the brake system and do not continue riding until the problem is eliminated (Your authorized workshop will be glad to help.)



#### Warning

**Danger of accidents** Old brake fluid reduces the braking effect

Make sure that brake fluid for the front and rear brake is changed in accordance with the service schedule. (Your authorized workshop will be glad to help.)

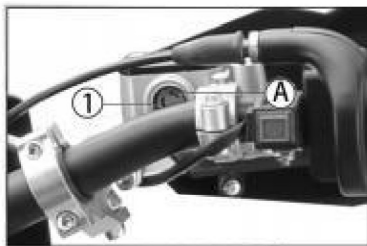

#### Preparatory work

Check the front brake linings .

#### Main work

Move the brake fluid reservoir mounted on the handlebar to a horizontal position

Check the brake fluid level in the viewer 1

If the brake fluid level is below the A marking

Add front brake fluid .

### 1 2 . 5 Adding front brake fluid



#### Warning

**Danger of accidents** An insufficient brake fluid level will cause the brake system to fall.

If the brake fluid level drops below the specified marking or the specified value, the brake system is leaking or the brake linings are worn down.

Check the brake system and do not continue riding until the problem is eliminated (Your authorized workshop will be glad to help.)



#### Warning

**Skin irritation** Brake fluid causes skin irritation.

Keep brake fluid out of the reach of children

Wear suitable protective clothing and safety glasses

Do not allow brake fluid to come into contact with the skin, the eyes or clothing

Consult a doctor immediately if brake fluid has been swallowed.

Rinse the affected area with plenty of water in the event of contact with the skin.

Rinse eyes thoroughly with water immediately and consult a doctor if brake fluid comes into contact with the eyes.

If brake fluid spills on to your clothing, change the clothing



#### Warning

**Danger of accidents** Old brake fluid reduces the braking effect

Make sure that brake fluid for the front and rear brake is changed in accordance with the service schedule. (Your authorized workshop will be glad to help.)



#### Warning

**Environmental hazard** Hazardous substances cause environmental damage

Dispose of oils, grease, filters, fuel, cleaning agents, brake fluid, etc.. correctly and in compliance with the applicable regulations.

## 12 BRAKESYSTEM

- i Info**  
 Never use DOT 5 brake fluid. It is silicone-based and purple in color. Oil seals and brake lines are not designed for DOT 5 brake fluid.  
 Avoid contact between brake fluid and painted parts. Brake fluid attacks paint.  
 Only use clean brake fluid from a sealed container.

### Preparatory work

Check the front brake linings .

### Main work

Move the brake fluid reservoir mounted on the handlebar to a horizontal position

Remove screws **1**.

Remove cover **2** with membrane **3**

Add brake fluid to level **A** .

Guideline

Level <b>A</b> (brake fluid level below reservoir rim)	5 mm (0.2 in)
--	---------------

Brake fluid DOT 4/DOT5 . 1

Position the cover with the membrane. Mount and tighten the screws.

- i Info**  
 Clean up overflowed or spilled brake fluid immediately with water

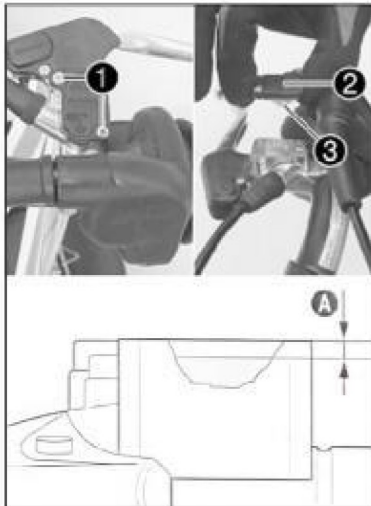

### 12.6 Checking the front brake linings

- Warning**  
**Danger of accidents** Worn-out brake linings reduce the braking effect

Ensure that worn-out brake linings are replaced immediately. (Your authorized workshop will be glad to help)

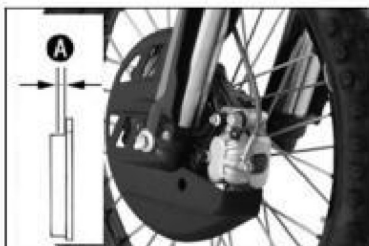

Check the brake linings for minimum thickness **A** .

Minimum thickness <b>A</b>	> 1 mm (> 0.04 in)
----------------------------	--------------------

If the minimum thickness is less than specified:

Change the front brake linings

Check the brake linings for damage and cracking.

If damage or cracking is visible:

Change the front brake linings .

### 12.7 Changing the front brake linings

- Warning**  
**Danger of accidents** incorrect maintenance will cause the brake system to fail.

Ensure that service work and repairs are performed professionally. (Your authorized workshop will be glad to help.)

## 12 BRAKESYSTEM



### Warning

**Skin irritation** Brake fluid causes skin irritation

Keep brake fluid out of the reach of children .

-Wear suitable protective clothing and safety glasses.

Do not allow brake fluid to come into contact with the skin. the eyes or clothing

Consult a doctor immediately if brake fluid has been swallowed

Rinse the affected area with plenty of water in the event of contact with the skin

Rinse eyes thoroughly with water immediately and consult a doctor if brake fluid comes into contact with the eyes.

If brake fluid spills on lo your clothing.change the clothing



### Warning

**Danger of accidents** Old brake fluid reduces the braking effect.

Make sure that brake fluid for the front and rear brake is changed in accordance with the service schedule.(Your authorized workshop will be glad to help.)



### Warning

**Danger of accidents** Oil or grease on the brake discs reduces the braking effect

Always keep the brake discs free of oil and grease.

Clean the brake discs with brake cleaner when necessary



### Warning

**Danger of accidents** Brake linings which have not been approved alter the braking efficiency.

Not all brake linings are tested and approved for motorcycles. The structure and friction coefficient of the brake linings, and thus their brake power, may vary greatly from that of original brake linings

If brake linings are used that differ from the original equipment, compliance with the original homologation is not guaranteed.

In this case, the vehicle no longer corresponds to its condition at delivery and the warranty shall be void

Only use brake linings approved and recommended by



### Warning

**Environmental hazard** Hazardous substances cause environmental damage.

Dispose of oils.grease.filters, fuel, cleaning agents, brake fluid,etc., correctly and in compliance with the applicable regulations .



### Info

Never use DOT 5 brake fluid.It is silicone-based and purple in color.Oil seals and brake lines are not designed for DOT5 brake fluid.

Avoid contact between brake fluid and painted parts.Brake fluid attacks paint.

Only use clean brake fluid from a sealed container

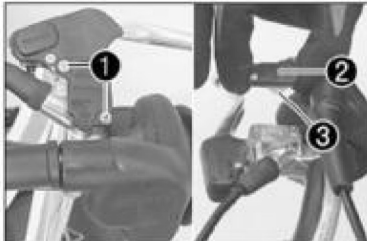

-Move the brake fluid reservoir mounted on the handlebar to a horizontal position

Remove screws 1 .

Remove cover 2 with membrane 3

Manually press the brake caliper toward the brake disc to push back the brake pistons. Ensure that brake fluid does not flow out of the brake fluid reservoir,if necessary extract excess.



### Info

Make sure that you do not press the brake caliper against the spokes when pushing back the brake pistons.

Remove cotter pins 4. pull out pin 5 .and remove the brakelinings .

Clean the brake caliper and brake caliper support.

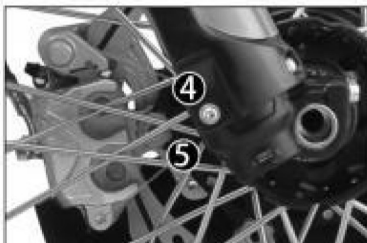

## 12 BRAKESYSTEM

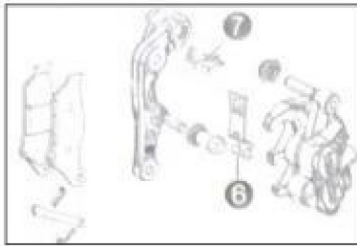

Check that leaf spring 6 in the brake caliper and sliding plate 7 in the brake caliper support are seated correctly.



Insert the new brake linings, insert the pin, and mount the cotter pins.

**i Info**

Always change the brake linings in pairs.

Operate the hand brake lever repeatedly until the brake linings are in contact with the brake disc and there is a pressure point.

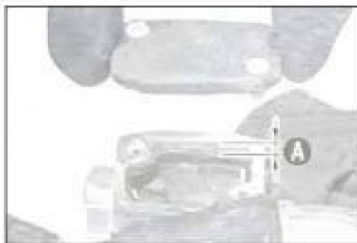

Correct the brake fluid quantity to level **A**

Guideline

Level <b>A</b> (brake fluid level below reservoir rim)	5 mm(0.2 in)
--	--------------

Brake fluid DOT 4/DOT 51
--------------------------

Position the cover with the membrane. Mount and tighten the screws.

**i Info**

Clean up overflowed or spilled brake fluid immediately with water.

### 12.8 Check the rear brake lever



**Warning**

**Danger of accidents** The brake system fails in the event of overheating

If there is no free travel on the foot brake lever, pressure builds up in the brake system on the rear brake

-Set the free travel on the foot brake lever in accordance with the specification.

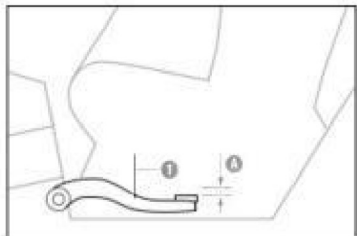

Disconnect spring 1.

Move the foot brake lever back and forth between the end stop and the contact to the foot brake cylinder piston and check free travel **A**.

Guideline

Free travel at foot brake lever	3...5 mm(0.12 ... 0.2 in)
---------------------------------	---------------------------

If the free travel does not meet specifications:

Adjust the basic position of the foot brake lever.

Reconnect spring 1

### 12.9 Adjusting the basic position of the foot brake lever



**Warning**

**Danger of accidents** The brake system fails in the event of overheating

If there is no free travel on the foot brake lever, pressure builds up in the brake system on the rear brake.

Set the free travel on the foot brake lever in accordance with the specification.

## 12 BRAKESYSTEM

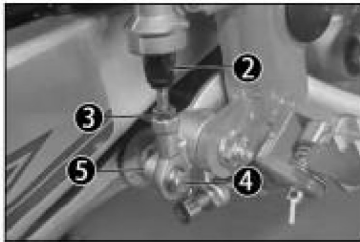
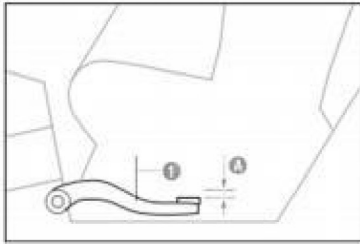

Detach spring 1

Loosen nut 2 and, with push rod 3, turn it back until you have maximum free travel

To adjust the basic position of the foot brake lever to individual requirements, loosen nut 4 and turn screw 5 accordingly

### **i** Info

The range of adjustment is limited

Turn push rod 3 accordingly until you have free travel A. If necessary, adjust the basic position of the foot brake lever.

Guideline

Free travel at foot brake lever	3...5 mm (0.12 ... 0.2 in)
---------------------------------	----------------------------

Hold screw 5 and tighten nut 4

Guideline

Nut, foot brake lever stop	M8	20 Nm (14.8 lbf ft)
----------------------------	----	------------------------

Hold push rod 3 and tighten nut 2.

Guideline

Remaining nuts, chassis	M6	10 Nm(7 .4lbf ft)
-------------------------	----	-------------------

Attach spring 1.

### 12.10 Checking the rear brake fluid level



#### **Warning**

**Danger of accidents** An insufficient brake fluid level will cause the brake system to fail.

If the brake fluid level drops below the specified marking or the specified value, the brake system is leaking or the brake linings are worn down.

Check the brake system and do not continue riding until the problem is eliminated. (Your authorized workshop will be glad to help)



#### **Warning**

**Danger of accidents** Old brake fluid reduces the braking effect.

Make sure that brake fluid for the front and rear brake is changed in accordance with the service schedule. (Your authorized workshop will be glad to help.)

#### **Preparatory work**

Check the rear brake linings.

#### **Main work**

Stand the vehicle upright.

Check the brake fluid level in level viewer 1.

If the brake fluid has dropped below marking A:

Add rear brake fluid.

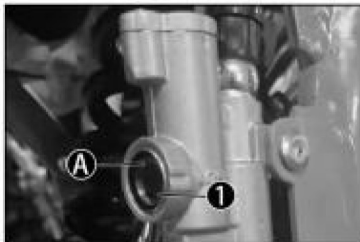

## 12 BRAKESYSTEM

### 12.11 Adding rear brake fluid



#### Warning

**Danger of accidents** An insufficient brake fluid level will cause the brake system to fail

If the brake fluid level drops below the specified marking or the specified value, the brake system is leaking or the brake linings are worn down.

Check the brake system and do not continue riding until the problem is eliminated (Your authorized workshop will be glad to help)



#### Warning

**Skin Irritation** Brake fluid causes skin irritation

Keep brake fluid out of the reach of children.

Wear suitable protective clothing and safety glasses.

Do not allow brake fluid to come into contact with the skin, the eyes or clothing

Consult a doctor immediately if brake fluid has been swallowed.

Rinse the affected area with plenty of water in the event of contact with the skin.

Rinse eyes thoroughly with water immediately and consult a doctor if brake fluid comes into contact with the eyes

If brake fluid spills on to your clothing, change the clothing



#### Warning

**Danger of accidents** Old brake fluid reduces the braking effect

Make sure that brake fluid for the front and rear brake is changed in accordance with the service schedule. (Your authorized workshop will be glad to help.)



#### Warning

**Environmental hazard** Hazardous substances cause environmental damage

Dispose of oils, grease, filters, fuel, cleaning agents, brake fluid, etc., correctly and in compliance with the applicable regulations



#### Info

Never use DOT 5 brake fluid. It is silicone-based and purple in color. Oil seals and brake lines are not designed for DOT 5 brake fluid

Avoid contact between brake fluid and painted parts. Brake fluid attacks paint.

Only use clean brake fluid from a sealed container

#### Preparatory work

Check the rear brake linings

#### Main work

Stand the vehicle upright

Remove screw cap 1 with membrane 2 and the O-ring

Add brake fluid to level **A**

Brake fluid DOT 4/DOT5. 1

Mount the screw cap with the membrane and the O-ring

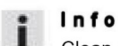

#### Info

Clean up overflowed or spilled brake fluid immediately with water.

### 12.12 Checking the rear brake linings



#### Warning

**Danger of accidents** Worn-out brake linings reduce the braking effect.

Ensure that worn-out brake linings are replaced immediately. (Your authorized workshop will be glad to help.)

## 12 BRAKESYSTEM



Check the brake linings for minimum thickness **A** .

Minimum thickness **A**  $\geq 1 \text{ mm} (\geq 0.04 \text{ in})$

If the minimum thickness is less than specified:

Change the rear brake linings .

Check the brake linings for damage and cracking

If damage or cracking is visible:

Change the rear brake linings .

### 12.13 Changing the rear brakelinings



#### Warning

**Danger of accidents** Incorrect maintenance will cause the brake system to fail.

Ensure that service work and repairs are performed professionally.(Your authorized workshop will be glad to help.)



#### Warning

**Skin irritation** Brake fluid causes skin irritation

Keep brake fluid out of the reach of children.

Wear suitable protective clothing and safety glasses.

Do not allow brake fluid to come into contact with the skin, the eyes or clothing.

Consult a doctor immediately if brake fluid has been swallowed.

Rinse the affected area with plenty of water in the event of contact with the skin

Rinse eyes thoroughly with water immediately and consult a doctor if brake fluid comes into contact with the eyes.

If brake fluid spills on to your clothing, change the clothing.



#### Warning

**Danger of accidents** Old brake fluid reduces the braking effect

Make sure that brake fluid for the front and rear brake is changed in accordance with the service schedule.(Your authorized workshop will be glad to help)



#### Warning

**Environmental hazard** Hazardous substances cause environmental damage

Dispose of oils, grease, filters, fuel, cleaning agents, brake fluid, etc., correctly and in compliance with the applicable regulations.



#### Info

Never use DOT 5 brake fluid It is silicone-based and purple in color.Oil seals and brake lines are not designed for DOT5 brake fluid.

Avoid contact between brake fluid and painted parts.Brake fluid attacks paint.

Only use clean brake fluid from a sealed container.

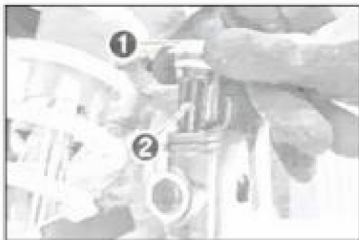

Stand the vehicle upright.

Remove screw cap **1** with membrane **2** and the O-ring

## 12 BRAKESYSTEM

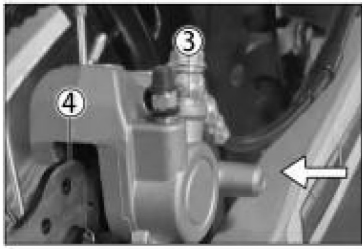

Manually press the brake caliper to the brake disc to push back the brake piston.  
Ensure that brake fluid does not flow out of the brake fluid reservoir, extracting it by suction if it does.



**Info**

Make sure when pushing back the brake piston that you do not press the brake caliper against the spokes

Remove cotter pins 3. pull out pin 4. and remove the brake linings.  
Clean the brake caliper and brake caliper support.

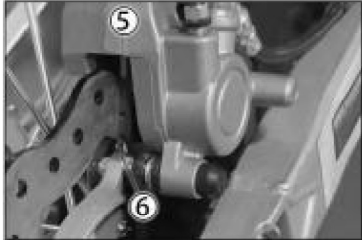

Check that leaf spring 5 in the brake caliper and sliding plate 6 in the brake caliper support are seated correctly.



**Info**

The arrow on the leaf spring points in the rotation direction of the brake disc.

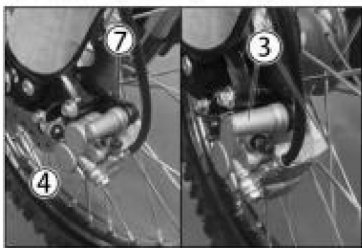

- Insert the new brake linings, insert pin 4 . and mount cotter pins 3 .



**Info**

Always change the brake linings in pairs.

Make sure that decoupling plate 7 is mounted on the piston side brake lining.

Operate the foot brake lever repeatedly until the brake linings are in contact with the brake disc and there is a pressure point.



Add brake fluid to level **A**

Brake fluid DOT 4/DOT5 . 1

Mount and tighten screw cap 1 with membrane 2 and the O-ring.



**Info**

Clean up overflowed or spilled brake fluid immediately with water.

## 13 WHEELS, TIRES

### 13.1 Removing the front wheel

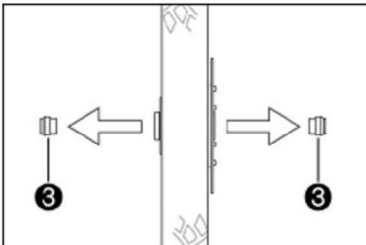
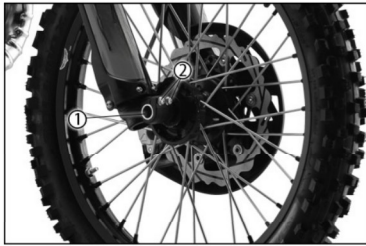
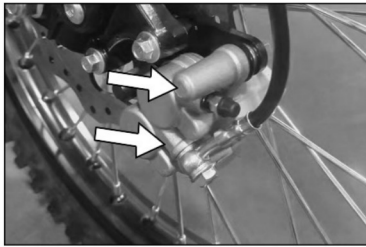

#### Preparatory work

Raise the motorcycle with a lift stand .

#### Main work

Press the brake caliper onto the brake disc by hand in order to push back the brake pistons.



#### Info

Make sure that you do not press the brake caliper against the spokes when pushing back the brake pistons

Loosen screw **1** by several rotations

Loosen screws **2**.

Press on screw **1** to push the wheel spindle out of the axle clamp

Remove screw **1**.



#### Warning

**Danger of accidents** Damaged brake discs reduce the braking effect.  
Always lay the wheel down in such a way that the brake disc is not damaged

Holding the front wheel, withdraw the wheel spindle. Take the front wheel out of the fork.



#### Info

Do not pull the hand brake lever when the front wheel is removed.

Remove spacers **3**

### 13.2 Installing the front wheel



#### Warning

**Danger of accidents** Oil or grease on the brake discs reduces the braking effect.

Always keep the brake discs free of oil and grease.

Clean the brake discs with brake cleaner when necessary.

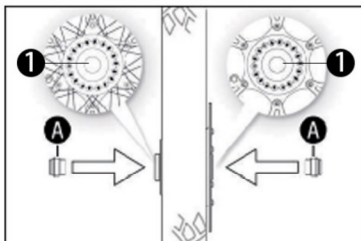

Check the wheel bearing for damage and wear.

If the wheel bearing is damaged or worn:

Change the front wheel bearing

Clean and grease shaft seal rings **1** and contact surface **A** of the spacers .

Long - life grease

Insert the spacers .

## 13 WHEELS, TIRES



Clean and grease the wheel spindle

Long-life grease

Lift the front wheel into the fork, position it, and insert the wheel spindle

The brake linings are correctly positioned.

Mount and tighten screw 2.

Guideline

Screw, front wheel spindle	M20x1.5	35 Nm (25.8 lbf ft)
----------------------------	---------	------------------------

Operate the hand brake lever several times until the brake linings are seated correctly against the brake disc.

Remove the motorcycle from the lift stand. ( p.38)

Operate the front brake and compress the fork a few times firmly

The fork legs straighten .

Tighten screws 3.

Guideline

Screw, fork stub	M8	15 Nm (11.1 lbf ft)
------------------	----	------------------------

### 1 3.3 Removing the rear wheel

#### Preparatory work

Raise the motorcycle with a lift stand .

#### Main work

Press the brake caliper onto the brake disc by hand in order to push back the brake piston

#### Info

Make sure when pushing back the brake piston that you do not press the brake caliper against the spokes.

Remove nut 1

Remove chain adjuster 2 . Withdraw wheel spindle 3 only enough to allow the rear wheel to be pushed forward.

Push the rear wheel forward as far as possible. Remove the chain from the rear Sprocket.

#### Info

Cover the components to protect them against damage



#### Warning

**Danger of accidents** Damaged brake discs reduce the braking effect

Always lay the wheel down in such a way that the brake disc is not damaged.

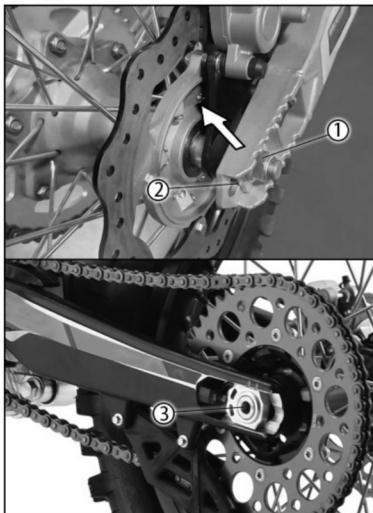

Holding the rear wheel, withdraw the wheel spindle. Take the rear wheel out of the swingarm

#### Info

Do not operate the foot brake lever when the rear wheel is removed.

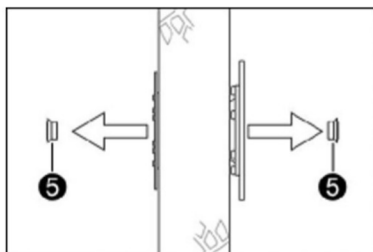

Remove spacers 5.

## 13 WHEELS, TIRES

### 13.4 Installing the rear wheel



#### Warning

**Danger of accidents** Oil or grease on the brake discs reduces the braking effect.

Always keep the brake discs free of oil and grease.

Clean the brake discs with brake cleaner when necessary

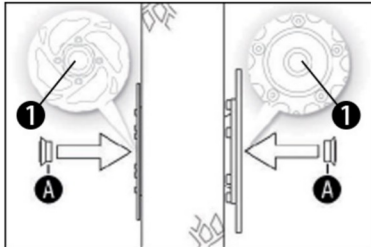

#### Main work

-Check the wheel bearing for damage and wear.

If the wheel bearing is damaged or worn

Change the rear wheel bearing

Clean and grease shaft seal rings 1 and contact surface A of the spacers.

Long-life grease

Insert the spacers

Clean and grease the wheel spindle.

Long-life grease

Position the rear wheel and insert wheel spindle 2

The brake linings are correctly positioned

Mount the chain.



Position chain adjuster 3. Mount nut 4, but do not tighten it yet.

Make sure that chain adjusters 3 are fitted correctly on adjusting screws 5.

Check the chain tension. ( p .55)

Tighten nut 4.

Guideline

Nut, rear wheel spindle	M25x1 .5	80 Nm (59 lbf ft)
-------------------------	----------	-------------------

#### Info

The wide adjustment range of the chain adjusters(32mm(1.26in)) enables different secondary ratios with the same chain length.

Chain adjusters 3 can be turned by 180°.

Operate the foot brake lever repeatedly until the brake linings are in contact with the brake disc and there is a pressure point.

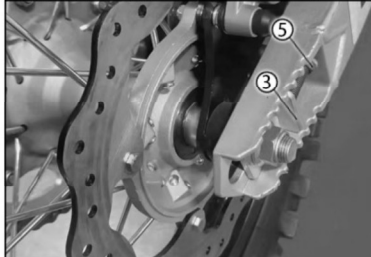
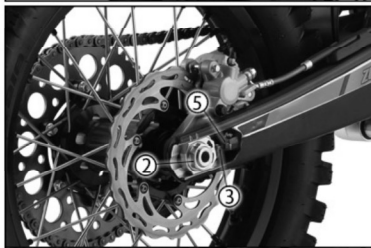

#### Finishing work

Remove the motorcycle from the lift stand

## 13 WHEELS, TIRES

### 13.5 Checking the tire condition



**Info**

Only mount tires approved and/ or recommended by  
 Other tires could have a negative effect on handling characteristics.  
 The type, condition, and air pressure of the tires all have a major impact on the handling of the motorcycle.  
 The tires mounted on the front and rear wheels must have a similar profile.  
 Worn tires have a negative effect on handling characteristics, especially on wet surfaces.

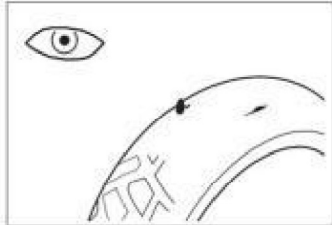

Check the front and rear tires for cuts, run-in objects, and other damage.  
 If the tires have cuts, run-in objects, or other damage  
 Change the tires.  
 Check the tread depth.



**Info**  
 Adhere to the legally required minimum tread depth.

minimum tread depth

≥2mm( ≥0.08 in)

If the tread depth is less than the minimum tread depth:  
 Change the tires.  
 Check the tire age.



**Info**

The tire date of manufacture is usually contained in the tire label and is indicated by the last four digits of the **DOT** number. The first two digits indicate the week of manufacture and the last two digits the year of manufacture.

recommends that the tires be changed after 5 years at the latest, regardless of the actual state of wear.

If the tires are more than 5 years old;  
 Change the tires.

### 13.6 Checking the tire air pressure



**Info**

Low tire air pressure leads to abnormal wear and overheating of the tire  
 Correct tire air pressure ensures optimal riding comfort and maximum tire service life.

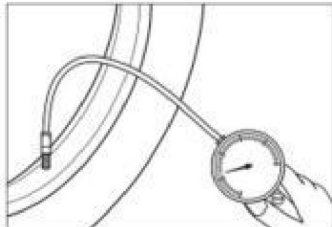

Remove the dust cap  
 Check the tire air pressure when the tires are cold

Tire air pressure off road

Front	1.0 bar(15 psi)
Rear	1.0 bar(15 psi)

If the tire pressure does not meet specifications:  
 Correct the tire pressure  
 Mount the dust cap

### 13.7 Checking spoke tension



**Warning**

**Danger of accidents** Incorrectly tensioned spokes impair the handling characteristic and result in secondary damage.  
 The spokes break due to being overloaded if they are too tightly tensioned. If the tension in the spokes is too low, then lateral and radial run-out will form in the wheel. Other spokes will become looser as a result.

Check spoke tension regularly, and in particular on a new vehicle. (Your authorized workshop will be glad to help.)

## 13 WHEELS, TIRES

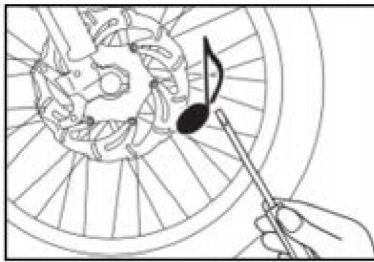

Strike each spoke briefly using a screwdriver blade.

**i** **Info**

The frequency of the sound depends on the spoke length and spoke diameter.

If you hear different tone frequencies from different spokes of equal length and diameter, this is an indication of different spoke tensions.

You should hear a high note.

If the spoke tension differs

Correct the spoke tension.

Check the spoke torque.

Guideline

Spoke nipple, front wheel	M4 .5	6 Nm(4 .4 lbf ft)
Spoke nipple, rear wheel	M4 .5	6 Nm(4.4 lbfft)

Torque wrench with various accessories in set

## 14 COOLING SYSTEM

### 14.1 Cooling system



Water pump in the engine ensures forced circulation of the coolant. The pressure resulting from the warming of the cooling system is regulated by a valve in radiator cap 2. This ensures that operating the vehicle at the specified coolant temperature will not result in a risk of malfunctions.

120° (248°F)

Cooling is effected by the air stream. The lower the speed, the less the cooling effect. Dirty cooling fins also reduce the cooling effect.

### 14.2 Radiator cover



The radiator cover is mounted in front of the left radiator between the radiator shield and radiator.

The radiator cover keeps the coolant temperature in the correct range.

Coolant temperature 65...70°C (149...158° F)



The radiator cover is installed in front of the left radiator, depending on the ambient temperature

Full radiator cover 1	<7 °C (<45 °F)
Half radiator cover 2	7 ... 16 °C (45 ... 61 °F)
No radiator cover	>16 °C (>61 °F)



#### Info

Do not use both radiator covers at the same time.

### 14.3 Installing the radiator cover

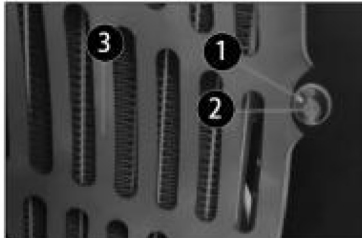

- Remove screws 1
- Remove screws 2
- Take off radiator shield 3.



Position the matching radiator cover. The larger catch is located at the top left.



#### Info

Do not use both radiator covers at the same time.

## 14 COOLING SYSTEM

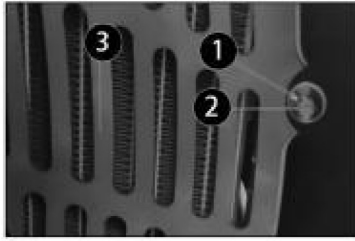

Position radiator shield **3**  
Mount and tighten screws **2**.  
Guideline

Remaining screws, chassis	M 6	10 Nm(7 .4 lbf ft)
---------------------------	-----	--------------------

Mount and tighten screws **1**

Guideline

Remaining screws, chassis	M 6	1 0 N m ( 7.4lbf ft)
---------------------------	-----	----------------------

### 14.4 Removing the radiator cover

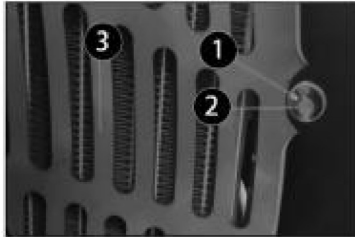

Remove screws **1**  
Remove screws **2**  
Take off radiator shield **3**  
Remove the radiator cover.  
Position radiator shield **3**  
Mount and tighten screws **2**.  
Guideline

Remaining screws, chassis	M6	10 Nm(7 .4 lbf ft)
---------------------------	----	--------------------

Mount and tighten screws **1**

Guideline

Remaining screws, chassis	M6	10 Nm(7 .4 lbf ft)
---------------------------	----	--------------------

### 14.5 Checking the antifreeze and coolant level



#### Warning

**Danger of scalding** During motorcycle operation, the coolant gets very hot and is under pressure.

Do not open the radiator, the radiator hoses or other cooling system components if the engine or the cooling system are at operating temperature.

Allow the cooling system and the engine to cool down before you open the radiator, the radiator hoses or other components of the cooling system

In the event of scalding, rinse the area affected immediately with lukewarm water



#### Warning

**Danger of poisoning** Coolant is toxic and a health hazard.

Keep coolant out of the reach of children.

Do not allow coolant to come into contact with the skin, the eyes and clothing.

Consult a doctor immediately if coolant is swallowed.

Rinse the affected area immediately with plenty of water in the event of contact with the skin.

Rinse eyes thoroughly with water and consult a doctor immediately if coolant gets into the eyes.

Change clothing if coolant spills onto your clothing.

#### Condition

The engine is cold

Stand the motorcycle upright on a horizontal surface

Remove the radiator cap.

Check the coolant antifreeze.

- 25 ... - 45 °C ( - 13 ... - 49 °F)

If the antifreeze in the coolant does not match the specified value Correct the coolant antifreeze.

Check the coolant level in the radiator .

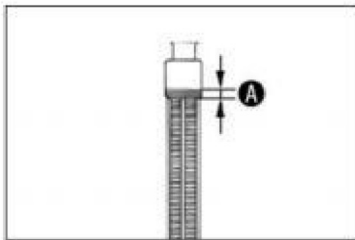

Coolant level <b>A</b> above the radiator) fins	10 mm (0.39 in)
---	-----------------

## 14 COOLING SYSTEM

If the coolant level does not match the specified value  
Correct the coolant level

Coolant

Mount the radiator cap

### 14.6 Checking the coolant level



#### Warning

**Danger of scalding** During motorcycle operation, the coolant gets very hot and is under pressure

Do not open the radiator, the radiator hoses or other cooling system components if the engine or the cooling system are at operating temperature.

Allow the cooling system and the engine to cool down before you open the radiator, the radiator hoses or other components of the cooling system

In the event of scalding, rinse the area affected immediately with lukewarm water



#### Warning

**Danger of poisoning** Coolant is toxic and a health hazard.

Keep coolant out of the reach of children

Do not allow coolant to come into contact with the skin, the eyes and clothing.

Consult a doctor immediately if coolant is swallowed.

Rinse the affected area immediately with plenty of water in the event of contact with the skin.

Rinse eyes thoroughly with water and consult a doctor immediately if coolant gets into the eyes.

Change clothing if coolant spills onto your clothing.

#### Condition

The engine is cold

Stand the motorcycle upright on a horizontal surface

Remove the radiator cap.

Check the coolant level in the radiator.

Coolant level **A** above the  
radiator fins

10 mm(0.39in)

If the coolant level does not match the specified value:

Correct the coolant level.

Coolant

Mount the radiator cap

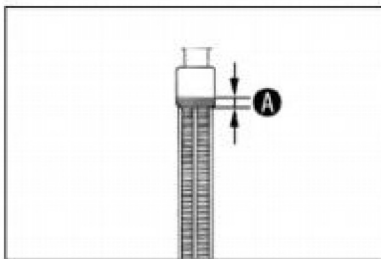

### 14.7 Draining the coolant



#### Warning

**Danger of scalding** During motorcycle operation, the coolant gets very hot and is under pressure.

Do not open the radiator, the radiator hoses or other cooling system components if the engine or the cooling system are at operating temperature.

Allow the cooling system and the engine to cool down before you open the radiator, the radiator hoses or other components of the cooling system.

In the event of scalding, rinse the area affected immediately with lukewarm water.



#### Warning

**Danger of poisoning** Coolant is toxic and a health hazard.

Keep coolant out of the reach of children.

Do not allow coolant to come into contact with the skin, the eyes and clothing.

Consult a doctor immediately if coolant is swallowed.

Rinse the affected area immediately with plenty of water in the event of contact with the skin .

Rinse eyes thoroughly with water and consult a doctor immediately if coolant gets into the eyes.

Change clothing if coolant spills onto your clothing.

## 14 COOLING SYSTEM

### Condition

The engine is cold

Position the motorcycle upright

- Place a suitable container under the water pump cover

Remove screw 1.

Completely drain the coolant

Mount and tighten screw 1 with a new seal ring .

Guideline

Drain plug, water pump cover	M6	8 Nm(5.9 lbf ft)
------------------------------	----	------------------



### 14.8 Refilling with coolant



#### Warning

**Danger of poisoning** Coolant is toxic and a health hazard.

Keep coolant out of the reach of children.

Do not allow coolant to come into contact with the skin, the eyes and clothing.

Consult a doctor immediately if coolant is swallowed.

Rinse the affected area immediately with plenty of water in the event of contact with the skin.

Rinse eyes thoroughly with water and consult a doctor immediately if coolant gets into the eyes

Change clothing if coolant spills onto your clothing.



Make sure that screw 1 is tightened.

Position the motorcycle upright.

Completely fill the radiator with coolant.

Coolant
---------



Loosen screw 2 until coolant escapes without bubbles

Mount and tighten screw 2

Guideline

Bleeder screw.cylinder head	M6	8 Nm(5.9 lbf ft)
-----------------------------	----	------------------

Completely fill the radiator with coolant.

Coolant
---------



Mount radiator cap 3



#### Danger

**Danger of poisoning** Exhaust gases are toxic and inhaling them may result in unconsciousness and death.

Always make sure there is sufficient ventilation when running the engine .

Use an effective exhaust extraction system when starting or running the engine in an enclosed space.

Allow the engine to warm up and cool down again

Check the coolant level.

## 15 SERVICE WORK ON THE ENGINE

### 15.1 Emptying the carburetor float chamber



#### **Danger**

**Fire hazard** Fuel is highly flammable.

The fuel in the fuel tank expands when warm and can escape if overfilled.

Do not refuel the vehicle in the vicinity of open flames or lit cigarettes.

Switch off the engine for refueling

Make sure that no fuel is spilled; particularly not on hot parts of the vehicle.

If any fuel is spilled, wipe it off immediately.

Observe the specifications for refueling



#### **Warning**

**Danger of poisoning** Fuel is poisonous and a health hazard.

Avoid skin eye and clothing contact with fuel

Immediately consult a doctor if you swallow fuel

Do not inhale fuel vapors.

- In case of skin contact, rinse the affected area with plenty of water.

Rinse the eyes thoroughly with water, and consult a doctor in case of fuel contact with the eyes.

Change your clothing in case of fuel spills on them.

Keep fuels correctly in a suitable canister, and out of the reach of children.



#### **Warning**

**Environmental hazard** Improper handling of fuel is a danger to the environment

Do not allow fuel to enter the groundwater, the soil, or the sewage system.



#### **Info**

Carry out this work with a cold engine.

Water in the float chamber results in malfunctioning.

#### **Preparatory work**

Turn handle 1 of the fuel tap to the OFF position.

Fuel no longer flows from the fuel tank to the carburetor

#### **Main work**

Place a cloth under the carburetor to capture the draining fuel.

Remove screw plug 1.

Fully drain the fuel.

Mount and tighten the screw plug.



### 15.2 Checking the gear oil level



#### **Info**

The gear oil level must be checked when the engine is cold.

#### **Preparatory work**

Stand the motorcycle upright on a horizontal surface

# 15 SERVICE WORK ON THE ENGINE

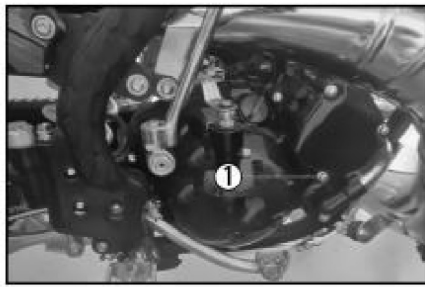

## Main work

Remove gear oil level check screw **1**.  
Check the gear oil level.

A small quantity of gear oil must run out of the drilled hole.

If no gear oil runs out:  
Add gear oil.

Mount and tighten the gear oil monitoring screw.

### Guideline

Screw gear oil level check	M6	8Nm (5.9lbf ft)
----------------------------	----	-----------------

## 15.3 Changing the gear oil

### Warning

 Danger of scalding Engine and gear oil get very hot when the motorcycle is ridden.

Wear suitable protective clothing and safety gloves.

In the event of scalding, rinse the area affected immediately with lukewarm water.

### Warning



Environmental hazard Hazardous substances cause environmental damage.

Dispose of oils, grease fillers, fuel, cleaning agents, brake fluid, etc., correctly and in compliance with the applicable regulations.

### Info

 Drain the gear oil while the engine is at operating temperature.

### Preparatory work

Park the motorcycle on a level surface.

Place a suitable container under the engine.

### Main work

Remove the gear oil drain plug with magnet **1**.

Remove gear oil drain plug **2**.

Let the gear oil drain fully.

Clean the gear oil drain plug thoroughly.

Clean the sealing surface on the engine.

Mount and tighten gear oil drain plug with the magnet **1** and the new seal ring.

### Guideline

Gear oil drain plug with magnet	M 12X 1.5	20 Nm (14.8 lbf ft)
---------------------------------	-----------	------------------------

Mount gear oil drain plug **2** with the new seal ring and tighten.

### Guideline

Gear oil drain plug	M 10x 1	15 Nm (11.1 lbf ft)
---------------------	---------	------------------------

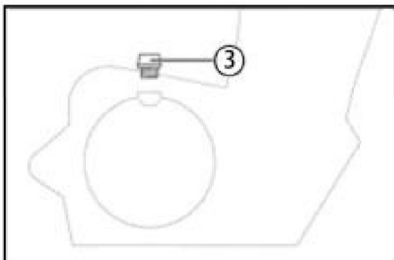
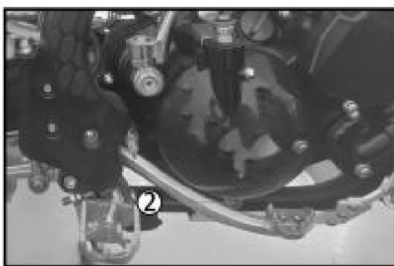
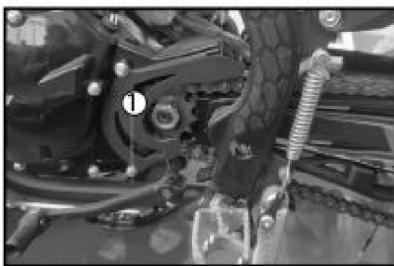

Remove filler plug **3** and fill up with gear oil.

Gear oil	0.80 l (0.85 qt.)	Engine oil (15W/50)
----------	-------------------	---------------------

Mount and tighten the oil filler plug

# 15 SERVICE WORK ON THE ENGINE



### Danger

Danger of poisoning Exhaust gases are toxic and inhaling them may result in unconsciousness and death.

Always make sure there is sufficient ventilation when running the engine.

Use an effective exhaust extraction system when starting or running the engine in an enclosed space.

Start the engine and check that it is oil-tight.

### Finishing work

Check the gear oil level.

## 15.4 Adding gear oil

### Info

Too little gear oil or poor-quality gear oil results in premature wear to the transmission.

Gear oil must only be topped up when the engine is cold.

### Preparatory work

Park the motorcycle on a level surface.

### Main work

Remove gear oil level check screw 1.

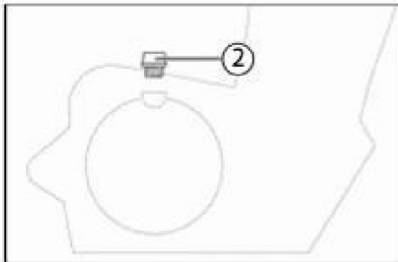

Remove filler plug 2

Add gear oil until it emerges from the drill hole of the gear oil monitoring screw. Engine oil(15W/50)

Mount and tighten the gear oil monitoring screw

### Guideline

Screw gear oil level check
----------------------------

M6
----

8 Nm (5.9 lbf ft)
-------------------

Mount and tighten filler plug 2.

### Finishing work



### Danger

Danger of poisoning Exhaust gases are toxic and inhaling them may result in unconsciousness and death.

Always make sure there is sufficient ventilation when running the engine.

Use an effective exhaust extraction system when starting or running the engine in an enclosed space.

Start the engine and check that it is oil-tight.

# 16 CLEANING, CARE

## 16.1 Cleaning the motorcycle

### Note

Material damage Components become damaged or destroy oil a pressure cleaner is used incorrectly  
The high pressure forces water into he electrical components. connectors. throttle cables, and bearings, etc  
Pressure which is too high causes malfunctions and destroys components.

Do not direct the water jet directly on to electrical components,connectors,throttle cables or bearings.

Maintain a minimum distance between the nozzle of the pressure cleaner and the component.

Minimum clearance 60 cm(23.6 in)



### Warning

Environmental hazard Hazardous substances cause environmental damage.

Dispose of oils,grease,filters,fuel,cleaning agents,brake fluid,etc., correctly and in compliance with the applicable regulations.



### Info

If you clean the motorcycle regularly, its value and appearance will be maintained over along period.

Avoid direct sunlight on the motorcycle during cleaning

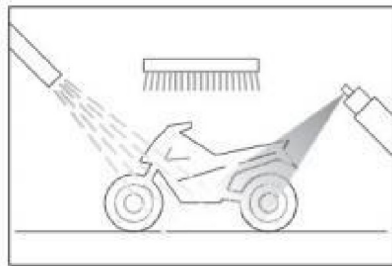

Close off the exhaust system to prevent water from entering.

Remove coarse dirt particles by spraying gently with water

Spray very dirty areas with a normal motorcycle cleaner and then clean with a soft brush.

Motorcycle cleaner



### Info

Use warm water containing normal motorcycle cleaner and a soft sponge.

Never apply motorcycle cleaner to the dry vehicle,always rinse with water first.

After rinsing he motorcycle win a gentle water spray, allow it to dry thoroughly.

Empty the carburetor float chamber.

Remove the plug from the exhaust system.



anger of accidents Moisture and dirt impair the brake system.

Brake carefully several times to dry out and remove dirt from the brake linings and the brake discs .

- After cleaning, take a short ride until the engine reaches operating temperature. -



### Info

The heat produced causes water at inaccessible locations in the engine and brake system to evaporate.

After the motorcycle has cooled off, lubricate all moving pars and bearings-

Clean the chain.

Treat bare metal parts(except for brake discs and exhaust system) with anti-corrosion materials.

Preserving materials for paints, metal and rubber

Treat all plastic parts and powder-coated parts with a mild cleaning and care product.

Special cleaner for glossy and matte paint finishes, metal and plastic surfaces

## 17 STORAGE

### 17.1 Storage



#### Warning

**Danger of poisoning** Fuel is poisonous and a health hazard.

Avoid skin, eye and clothing contact with fuel.

Immediately consult a doctor if you swallow fuel.

Do not inhale fuel vapors.

In case of skin contact, rinse the affected area with plenty of water.

Rinse the eyes thoroughly with water, and consult a doctor in case of fuel contact with the eyes.

Change your clothing in case of fuel spills on them.

Keep fuels correctly in a suitable canister, and out of the reach of children.



#### Info

If you plan to garage the motorcycle for a longer period, perform the following steps or have them performed.

Before storing the motorcycle, check all parts for function and wear. If service, repairs, or replacements are necessary, you should do this during the storage period (less workshop overload). In this way, you can avoid long workshop waiting times at the start of the new season.

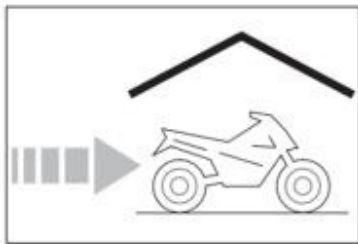

When refueling for the last time before taking the motorcycle out of service, add fuel additive.

Fuel additive

Refuel .

Clean the motorcycle.

Change the gear oil

Check the antifreeze and coolant level.

Empty the carburetor float chamber .4

Check the tire air pressure .

Store the vehicle in a dry location that is not subject to large fluctuations in temperature.



#### - Info -

recommends jacking up the motorcycle.

Raise the motorcycle with a lift stand .

Cover the vehicle with a tarp or similar cover that is permeable to air.



#### Info

Do not use non-porous materials since they prevent humidity from escaping, thus causing corrosion

Avoid running the engine for a short time only. Because the engine will not warm up sufficiently, the water vapor produced during combustion will condense, causing engine parts and the exhaust system to rust.

### 17.2 Preparing for use after storage

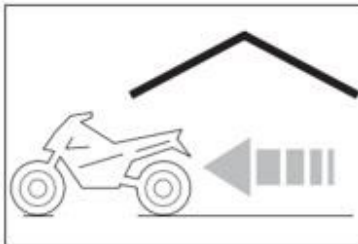

Remove the motorcycle from the lift stand.

Perform checks and maintenance measures when preparing for use.

Make a test ride.

## 18 TROUBLESHOOTING

Faults	Possible cause	Action
Engine turns but does not start	Operating error Motorcycle was out of use for a long time and there is old fuel in the float chamber	Carry out the start procedure Empty the carburetor float chamber
	Fuel feed interrupted	Check the fuel tank breather. Clean the fuel tap Check/ set the carburetor components
	Spark plug oily or wet	Clean and dry the spark plug . or change it if necessary.
	Electrode distance (plug gap) of spark plug too wide	Adjust the plug gap Guideline Spark plug electrode gap 0.60mm(0 0236 in)
	Fault in ignition system	Check the ignition system
	Kill switch cable in wiring harness frayed .kill switch defective	Check the kill switch.
	The connector or ignition coil is loose or oxidized	- Clean the connector and treat it with contact spray.
Engine has no idle	Water in carburetor or jets blocked	- Check/ set the carburetor components.
	Idling jet blocked	- Check/ set the carburetor components
	Adjusting screws on carburetor distorted	- Carburetor-adjust the idle speed.
	Spark plug defective	Change the spark plug .
Engine does not speed up	Ignition system defective	- Check the ignition coil. Check the spark plug connector.
	Carburetor running over because float needle dirty or worn	- Check/ set the carburetor components.
	Loose carburetor jets	- Check/ set the carburetor components.
Engine has too little power	Fault in ignition system	- Check the ignition system .
	Fuel feed interrupted	Check the fuel tank breather. -Clean the fuel tap. Check/ set the carburetor components.
	Air filter very dirty	Clean the air filter and air filter box.
	Exhaust system leaky, deformed or too little glass fiber yarn filling in main silencer	Check exhaust system for damage. Change glass fiber yarn filling in the main silencer.
	Diaphragm or reed valve housing damaged	Check the diaphragm and reed valve housing .
Engine stalls or is popping into the carburetor	Lack of fuel	Turn handle 1 of the fuel tap to the ON position .(Figure K00858- 10 p. 13) Refuel.
	Engine takes in bad air	Check the intake flange and carburetor for tightness.
	The connector or ignition coil is loose	Clean the connector and treat it with contact
Engine overheats	or oxidized	spray Check the cooling system for leakage
	Too little coolant in cooling system	Check the coolant level .
	Too little air stream	Switch off engine when stationary.
	Radiator fins very dirty	Clean the radiator fins.
	Foam formation in cooling system	Drain the coolant . Refill with coolant
	Damaged cylinder head or cylinder head gasket	Check the cylinder head and cylinder head gasket

## 18 TROUBLESHOOTING

Faults	Possible cause	Action
Engine overheats	Bent radiator hose	- Change the radiator hose .
	Incorrect ignition point due to loose stator	- Adjust the ignition.
White smoke emission (steam in exhaust gas)	Damaged cylinder head or cylinder head gasket	- Check the cylinder head and cylinder head gasket.
Gear oil exits at the vent hose	Too much gear oil added	- Check the gear oil level
Water in the gear oil	Damaged shaft seal ring or water pump	- Check the shaft seal ring and water pump.

# 19 TECHNICAL DATA

## 19.1 250 Engine

Design	1 - cylinder 2 - stroke engine, water-cooled,
Displacement	249cm
Stroke	64mm
Bore	66.8 mm
Clutch	Automation Wet Multi-Plate
Gearbox	6 - gear(1-0-2-3-4-5-6 )
Transmission ratio	
First gear	2.750
Second gear	1.875
Third gear	1.411
Fourth gear	1.143
Fifth gear	0.956
Sixth gear	0.818

## 20 SUBSTANCES

### Brake fluid DOT4/DOT5.1

Standard/classification

DOT

**Guideline**

Use only brake fluid that complies with the specified standard( see specifications on the container) and that exhibits the corresponding Properties.

Recommended supplier

Castrol

**REACTPERFORMANCEDOT4**

**Brake Fluid DOT 5.1**

### Coolant

**Guideline**

Only use high-grade, silicate-free coolant with corrosion inhibitor additive for aluminum motors. Low grade and unsuitable antifreeze causes corrosion, deposits and frothing.

Do not use pure water as only coolant is able to meet the requirements needed in terms of corrosion protection and lubrication properties

Only use coolant that complies with the requirements stated(see specifications on the container) and that has the relevant properties

Antifreeze protection to at least	-25°C (-13°F)
-----------------------------------	---------------

The mixture ratio must be adjusted to the necessary antifreeze protection. Use distilled water if the coolant needs to be

diluted The use of premixed coolant is recommended.

Observe the coolant manufacturer specifications for antifreeze protection, dilution and miscibility(compatibility) with other coolants

### Engine oil(5W/40)

**Standard/ classification**

- JASO T903 MA

- S A E (5W/40)

**Guideline**

- Use only engine oils that comply with the specified standards( see specifications on the container) and that possess the corresponding properties.

### Engine oil, 2-stroke

**Standard/ classification**

JASO FD

**Guideline**

Only use high grade 2-stroke engine oil of a reputable brand.

Fully synthetic
-----------------

Recommended supplier

**Cross Power 2T**

## 21 SUBSTANCES

### Fork oil(SAE 4)(48601166 S1)

Standard/classification

SAE(SAE 4)

**Guideline**

Use only oils that comply with the specifications standards(see specifications on the container) and that exhibit the corresponding properties.

### Shock absorber fluid(SAE 2 .5)(50180751 S1)

Standard/classification

SAE(SAE 2 .5)

**Guideline**

Use only oils that comply with the specified standards(see specifications on the container)and that exhibit the corresponding properties.

### Super unleaded( ROZ98 / RON98 / PON94 )

Standard/classification

DIN EN 228(ROZ 98/RON 98/PON 94)

### Super unleaded(98 octane) mixed with 2-strokeengineoil(1:40)

Standard/classification

- DIN EN 228
- JASO FD(1:40)

**Mixture ratio**

1:40

Engine oil, 2-stroke  
Super unleaded(ROZ98/RON 98/PON 94)